



## **FORMATION EVALUATION MANUAL**

By Prof Dr. Sc., PhD **Elnur Amirov** (Baku Higher Oil School, Khazar University and Heriot Watt University).

e-mails: [e.amirov@hw.ac.uk](mailto:e.amirov@hw.ac.uk) & [eamirov@khazar.org](mailto:eamirov@khazar.org)

### **FORMATION EVALUATION**

The ultimate objective of well logging in the petroleum industry is to economically establish the existence of producible hydrocarbon reservoirs (oil and gas).

A reservoir may be defined as a rock which has both porosity and permeability. The factors which determine porosity and/or permeability are the:

- ✓ Depositional environment
- ✓ Subsequent diagenesis.

Hence, identifying or understanding of such phenomena is important prior to any well evaluation.

### **OBJECTIVES OF RESERVOIR EVALUATION:**

The following are the essential objectives of reservoir evaluation by using well log.

- ✓ The location of a reservoir vertically within drilled section & if possible, spatially.
- ✓ Determination of fluid type- gas, oil, water, bitumen etc.
- ✓ Calculations of reserves, both movable & inplace.
- ✓ Computation of porosity (total, primary, secondary, effective).
- ✓ Computation of water saturation.
- ✓ Calculation of pay thickness.
- ✓ Selection of cutoffs.
- ✓ Determination of reservoir geometry.

## **INTRODUCTION:**

Once the prospect generation is made based on seismic and geological surveys, location for drilling is released based on the most probable structure in the hydrocarbon point of view. The most probable structure is based on the structure identified with

1. A mature source rock
2. A migration path connecting source rock to reservoir rock
3. A suitable reservoir rock (porous & permeable)
4. A trap
5. An impermeable seal

After the identification of the structure, location is released for drilling. Once the well is drilled, the need arises for ascertaining the worthiness of the well. Till the time the well is being drilled it is not sure that the well drilled will bear hydrocarbon. To ascertain the potential of the well it is required to Log the well.

## **WHAT IS LOGGING**

Logging, electro logging or well logging means continuous recording of a physical parameter of the formation with depth. The primary objectives of the wire line logging are

- ✓ The identification of reservoir
- ✓ The estimation of hydrocarbon in place.
- ✓ The estimation of recoverable hydrocarbon.

Well logs are results of several geophysical measurements recorded in a well bore. They consist of key information about formation drilled ie.,

1. To identify the productive zones of hydrocarbon.
2. To define the petrophysical parameters like porosity, permeability, hydrocarbon, saturation and lithology of zones.
3. To determine depth, thickness, formation temperature and pressure of a reservoir.
4. To distinguish between oil, gas and water zones in a reservoir.
5. To measure hydrocarbon mobility.

## METHOD OF LOGGING AND ACQUIRED DATA FORMAT

A schematic below shows a well logging setup.

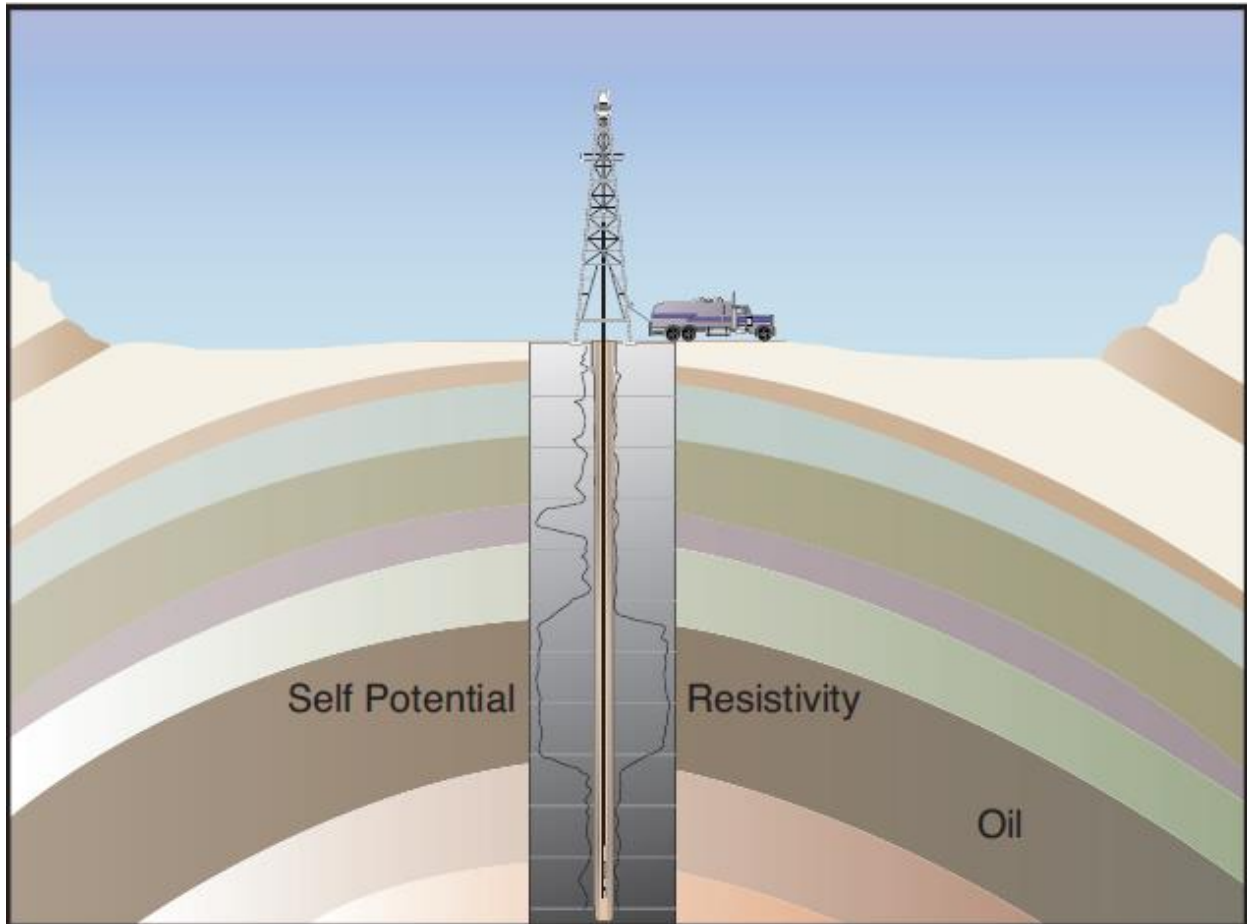

### WELL LOGGING SERVICES

Well logging services are broadly classified into open hole logging, cased hole logging, production logging and other services such as Plug setting, Perforations String shot etc.

## **PROCEDURE FOR LOGGING OPERATIONS**

Type of Logging operations to be carried out at various rigs is decided based on the requirement of the well. These jobs are carried out by track mounted logging units. The logging tools are lowered in to the well with the help of logging cable. For lowering the tools with logging cable two sheaves are used. The bottom sheave is tied with derrick floor and placed near the well mouth and the top sheave is hung to the traveling block so that the tools are lowered into the well. The tools are assembled and connected to logging cable through a rope socket on the catwalk and tested/calibrated prior to lowering into the well. The tool is lowered to the desired depth and data is acquired while the tool is pulled up. After completing the survey the Tool is pulled out and rig down process is initiated. **The logging procedure covers the following steps**

1. Parking of logging unit
2. Rig up (Fixing of top & bottom sheaves)
3. Stacking the tools and testing before lowering the tools
4. Lowering the tool in to the well at the desired depth
5. Logging Process
6. Pulling out the tool to the surface
7. Rig Down

Logs are recorded to measure different physical parameter of a well to ascertain the capacity of the well to flow hydrocarbon as mentioned above. It is also called as the electronic eye of a well. There are many physical parameters that can be recorded in Logs depending upon the need. However there are a very few basic parameters which are essential to be recorded in every well. They are broadly classified as

- 1) Resistivity Logs
- 2) Porosity/Radioactive Logs
- 3) Sonic/Acoustic Logs
- 4) Sampling and coring
- 5) Cement evaluation Log
- 6) Production Logs.

Let's review these logs one by one

### **RESISTIVITY LOGGING**

The resistivity of a substance is its ability to impede the flow of electric current through the substance. Formation resistivity usually falls in the range from 0.2 to 1000 ohm meter. Resistivity higher than 1000 ohm-m is uncommon in permeable formations. In a formation containing oil or gas, both of which are electrical insulators resistivity is a function of formation factor, brine resistivity and water saturation which in term depends on true resistivity. Of the formation parameters resistivity is of particular importance because it is essential for saturation determination mainly of the hydrocarbon. Depending upon the environment under which resistivity logs are recorded. There are two types of resistivity Logs. They are Latero logs and Induction logs.

### **DUAL LATERAL LOG**

The dual lateral log has been one of primary resistivity measurement device. DLL is a focused electrode device designed to minimize influence from borehole fluids and adjacent

formations. The DLL consists of an electronics section and a mandrel section. The mandrel supports the electrodes which are connected to the electronic circuitry. The measurement current emitted from center electrode is forced to flow laterally into the formation by the focusing action of electrodes surrounding the center electrode. It provides two measurements of the subsurface resistivity simultaneously. The two measurements have differing depth of investigation are called deep resistivity ( $R_d$ ) and shallow resistivity ( $R_s$ ).

### THEORY

DLL consist of a current emitting center electrode positioned between guard electrodes. A known current is passed through the current electrode with a return electrode at the surface. Simultaneously a potential is applied to the focused electrode to keep zero potential difference between guard and center electrode thereby the current is focused into the formation. Thus the potential difference produced is equivalent to the formation resistivity. The lateral log current path is basically a series circuit consisting of the drilling fluid, Mud cake, flushed zone, invaded zone and the virgin zone, with the largest voltage drop occurring over the highest resistance zone.

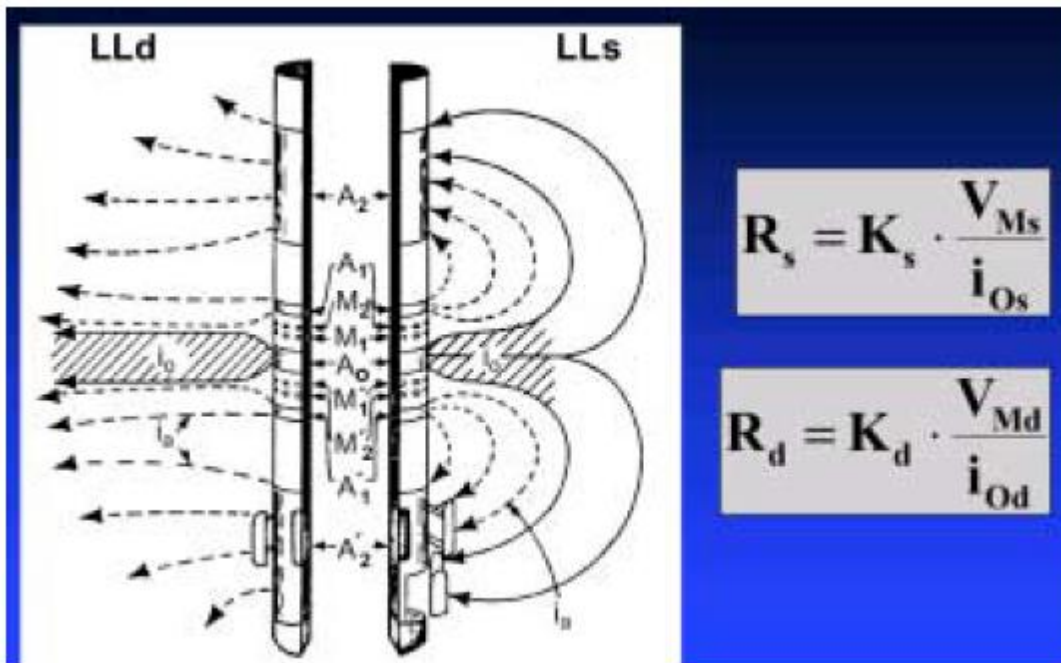

The total amount of current emanating from an electrode must flow through any Medium that encompasses the electrode. The depth of investigation of a lateral log is defined as the depth at which 50% of the total measured voltage is dropped.

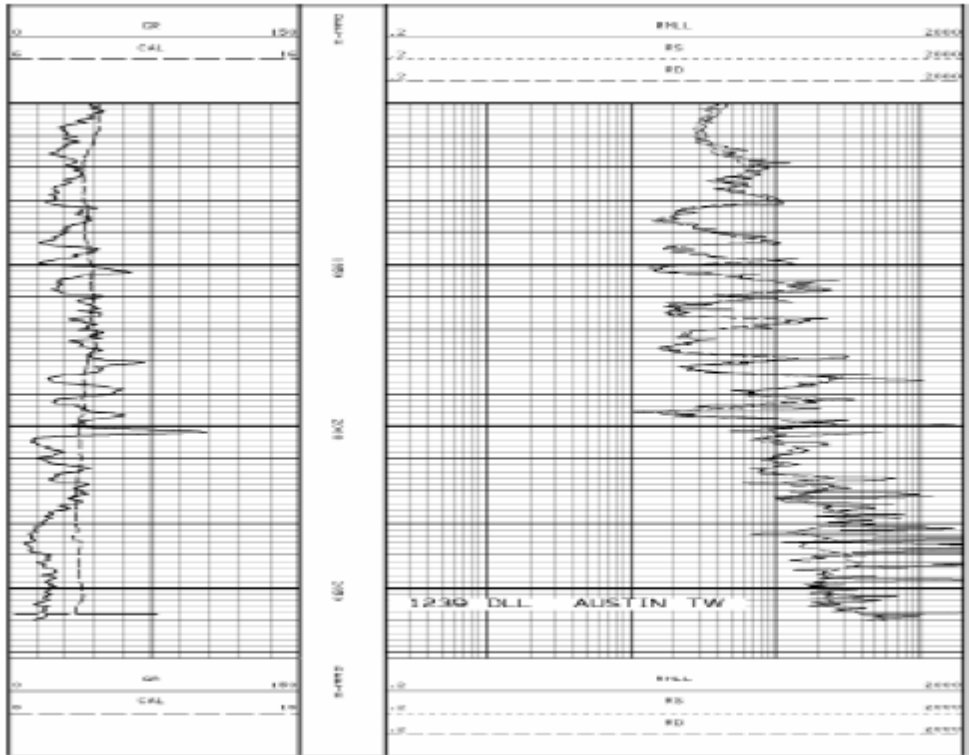

Standard 4 cycle log grid (DLL)

### Micro Laterolog/Micro Spherically Focused Logs

MLL is pad device. MLL has small vertical resolution and depth of investigation.  
Used to determine

$R_{xo}$ , Exact thickness of formation beds.

$R_{xo}$  can be used with archie's equation to calculate the saturation of the flushed zone

$$S_{xo} = \sqrt{(a / \phi_m) * (R_{xo} / R_{mf})}$$

Archie's equation, rewritten for saturation of the flushed zone, to determine moveable oil.

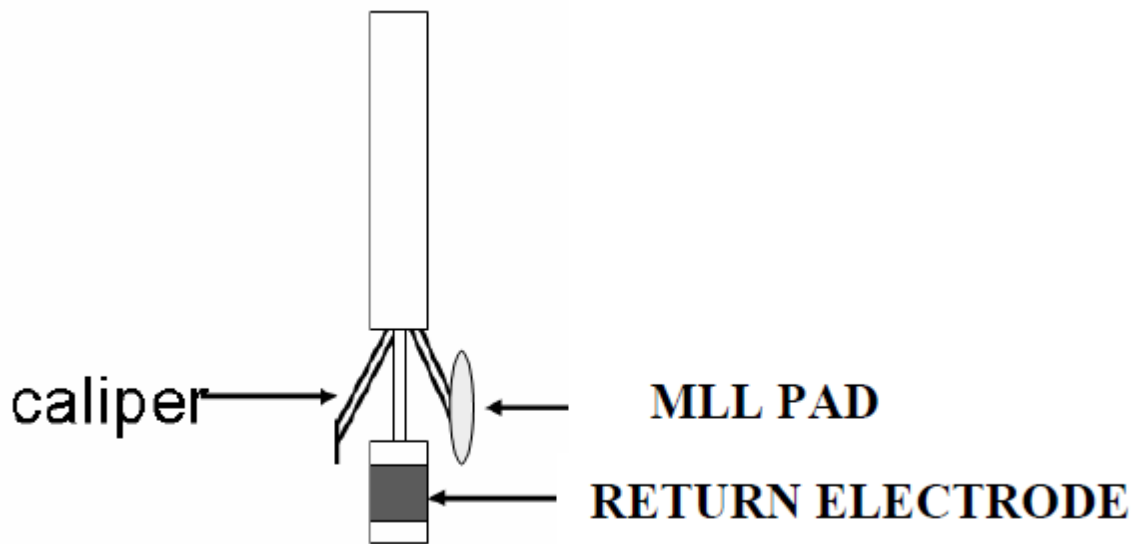

### Theory

Current from a measure electrode is forced into the flushed zone by guard electrodes returning to the return electrode. The current to the measure electrode is measured as is the voltage with regard to the ground.

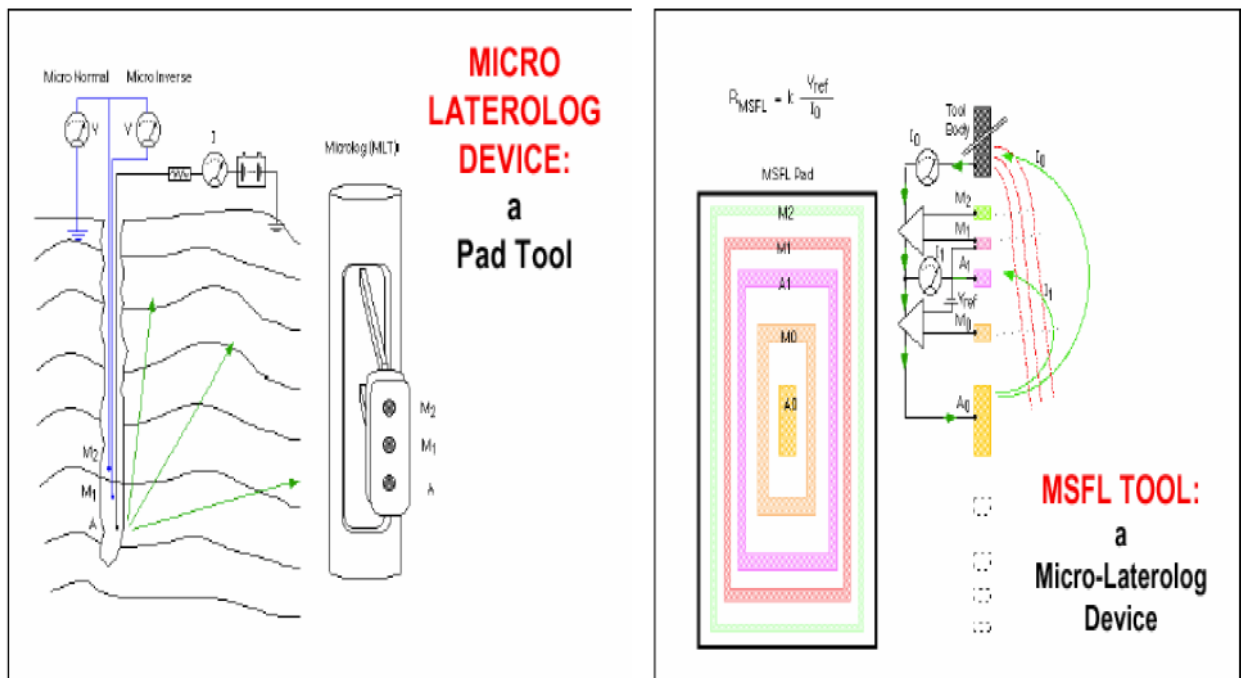

The MLL is a single tool contains an arm with the pad attached. The central electrode is the measure electrode. The eight other electrodes are guard electrodes.

## INDUCTION LOGGING

### PRINCIPLE

Induction tools are based on principles of electromagnetic induction. A magnetic field is generated by an AC electrical current flowing in a continuous loop/transmitter coil. The magnetic field from the transmitter coil induces ground loop currents in the formation. These ground current loops will in turn have an associated alternating magnetic field which will induce a voltage in the receiver coil, the magnitude of which is proportional to the formation conductivity.

- ✓ It works in oil based muds and air filled holes where latero tool fails.
- ✓ Tool accuracy is excellent for formations having low to moderate resistivity (up ~100 Ohm.m)
- ✓ The Dual Induction Latero (DIL) tool records three resistivity curves having different depths of investigation (ILD, ILM & LL3)

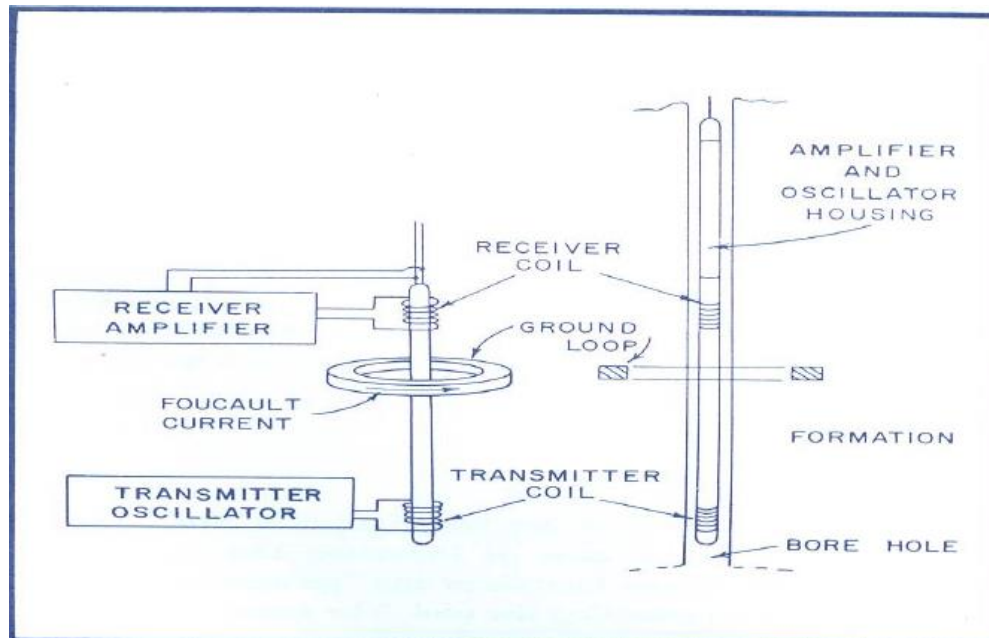

Principle of Induction Logging

### Applications of Resistivity Logs

- ✓ True formation resistivity and flushed zone resistivity.
- ✓ Mud filtrate invasion profile.
- ✓ Quick look hydrocarbon detection.
- ✓ Indication of producible hydrocarbon
- ✓ Correlation of different formations



## POROSITY LOG

Porosity values can be obtained from sonic log, a formation density log or a neutron log. In addition to porosity these logs are affected by other parameters, such as lithology, nature of the pore fluids, and shaliness. For more accurate porosity is obtained from combination of logs.

The readings of these tools are determined by the properties of formation close to the borehole. The sonic log has the shallowest investigation. Neutron and density logs are affected by a little deeper region, depending somewhat on the porosity, but generally within the flushed zone.

## NEUTRON LOG PRINCIPLE

In Neutron log we use a chemical source such as Americium-Beryllium/Neutron bulb which provides the emission of neutrons as continuous source of energy of about 4.5 MeV/14 MeV. When neutrons collides with nucleus of the atoms in the formation the neutron losses its energy and excites the nucleus of the atoms in the formation. When the excited nucleus returns back to its normal state, it emits Gamma ray characteristic to the atom. The analysis of the  $\gamma$ -ray spectrum identifies the composition of the elements in the formation: C, H, Cl, O etc. When the energy of the neutron reduces to thermal level and collides with Hydrogen atom its energy reduces to 0.025eV, also the neutrons are captured emitting gamma ray. Thus the uncaptured neutron reaching the detector is a measure of Hydrogen index of the formation.

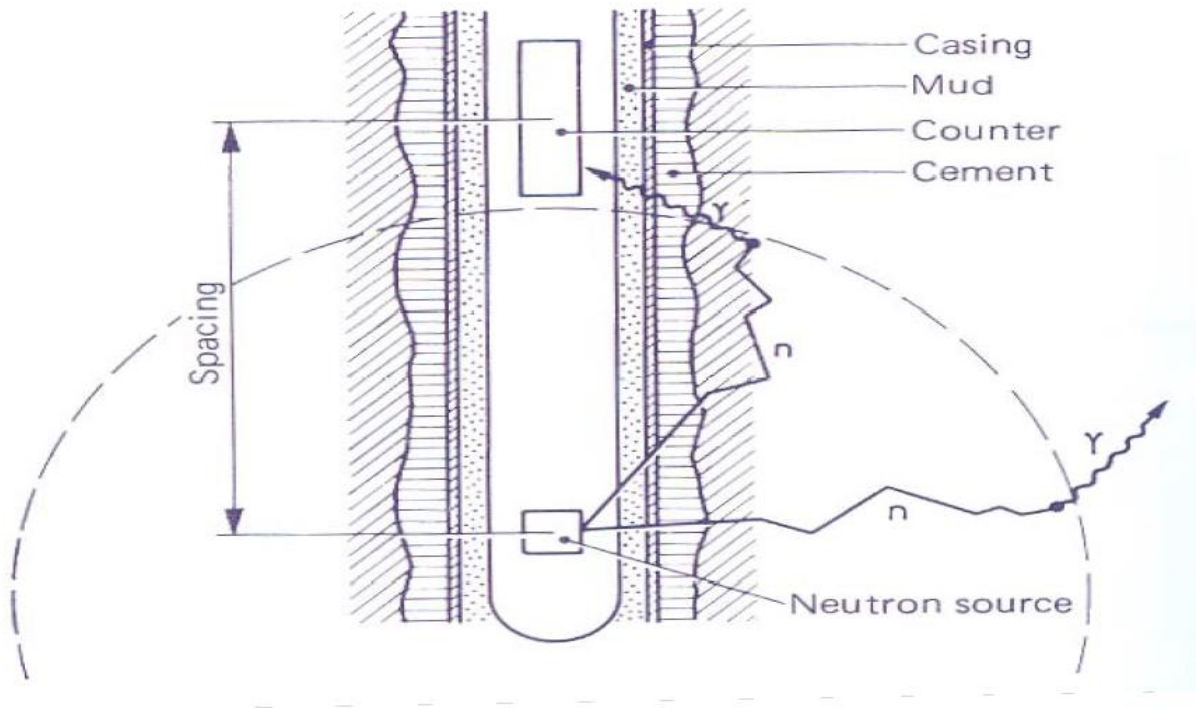

# Neutron Logging

- Source: Neutron source (chemical or electronic),
- Detectors: Neutron (thermal or epithermal)
- Measures neutron porosity (counts) which is a measure of the hydrogen index of the formation (H in the rock)
- HI in shales high
- HI of Gas  $\ll$  HI of water and oil

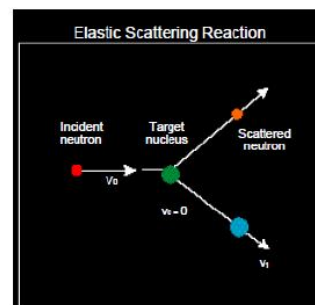

Large HI  
High NEU Porosity  
Low Count Rate

Low HI  
Low NEU Porosity  
High Count Rate

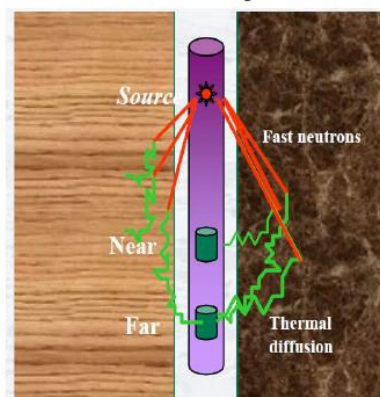

## Applications:

- Lithology (w/ DEN or Sonic)
- Gas identification (w/ DEN or Sonic)
- Correcting porosity for lith. and HC effects (w/ DEN or Sonic)
- Quantification of Gas fraction (w/ DEN or Sonic)
- Porosity (w/ DEN or Sonic)
- VSH

## PRINCIPLE OF NEUTRON TOOL

### ADVANTAGES

- ✓ Determination of Porosity.
- ✓ Lithology identification
- ✓ Water saturation.
- ✓ Gas detection.
- ✓ Location & Monitoring of gas / oil and water / oil contacts.
- ✓ Correlation with open hole resistivity logs.
- ✓ Shale indicator.

## BOREHOLE COMPENSATED SONIC LOG PRINCIPLE

The sonic tool measures the interval transit time,  $\Delta_t$  or the time in microsecond for an acoustic wave to travel through one foot formation, along a path parallel to the borehole, which is the reciprocal of the velocity of the compressional sound wave. Wyllie proposed the following empirical relation for determination of porosity from the sonic log:

$$\phi = (\Delta_{t \text{ log}} - \Delta_m) / (\Delta_{t \text{ fluid}} - \Delta_m)$$

Where  $\Delta_{t \text{ fluid}}$  and  $\Delta_m$  are the transit times in the pore fluid and rock matrix, respectively. This time average relation is good for clean, compacted formations of intergranular porosity containing liquids.

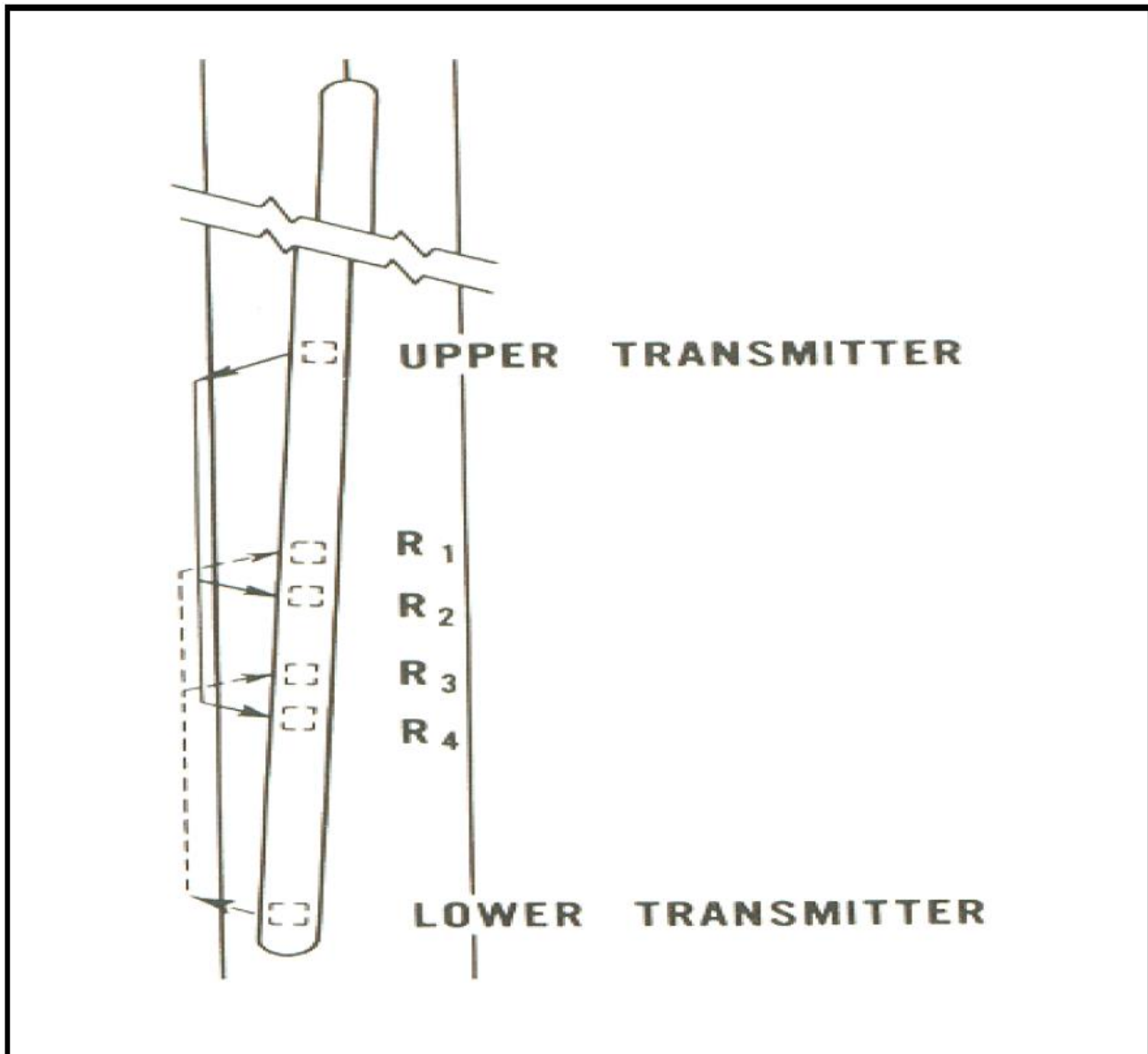

## PRINCIPLE OF ACOUSTIC TOOL

### TOOL CONFIGURATION

The tool mainly consists of upper transmitter, lower transmitter and two pairs of receiver. The transmission from T1 is recorded by the receiver followed by T2 and vice versa for compensating the effects as sonde tilt and rugose hole condition.

First 't' reading =  $(T1 - R1) - (T1 - R2)$

Second 't' reading =  $(T1 - R2) - (T2 - R2)$

T = (Memorized first 't' reading) plus (Second 't' reading) / 2 \* span

### ADVANTAGES

- ✓ Effects of cement coverage can be easily measured by comparing both open and cased hole data. (The transmit time overlying each other for good cement).
- ✓ Detection of hydrocarbon in high porosity sand.
- ✓ Lithology can be identified.
- ✓ Integrated travel time useful in seismic interpretation.

### LIMITATION

- ✓ In unconsolidated formations.
- ✓ Formation fractures.
- ✓ Gas saturations.
- ✓ Aerated muds.
- ✓ Rugose salt sections.

## DENSITY LOG

### PRINCIPLE

The density measures formation bulk density and photo electric absorption index of the lithologic column penetrated. The  $\delta_b$  density depends on fluid density and matrix density in porous formation, and  $P_e$  depends on atomic number used to determine the lithology of formation. To measure  $\delta_b$  and  $P_e$  gamma rays are directed to the formation. The detectors measure the gamma ray flux resulting from scattering and absorption effect of the formation. The higher the formation density, the lower the gamma ray intensity at the detectors.

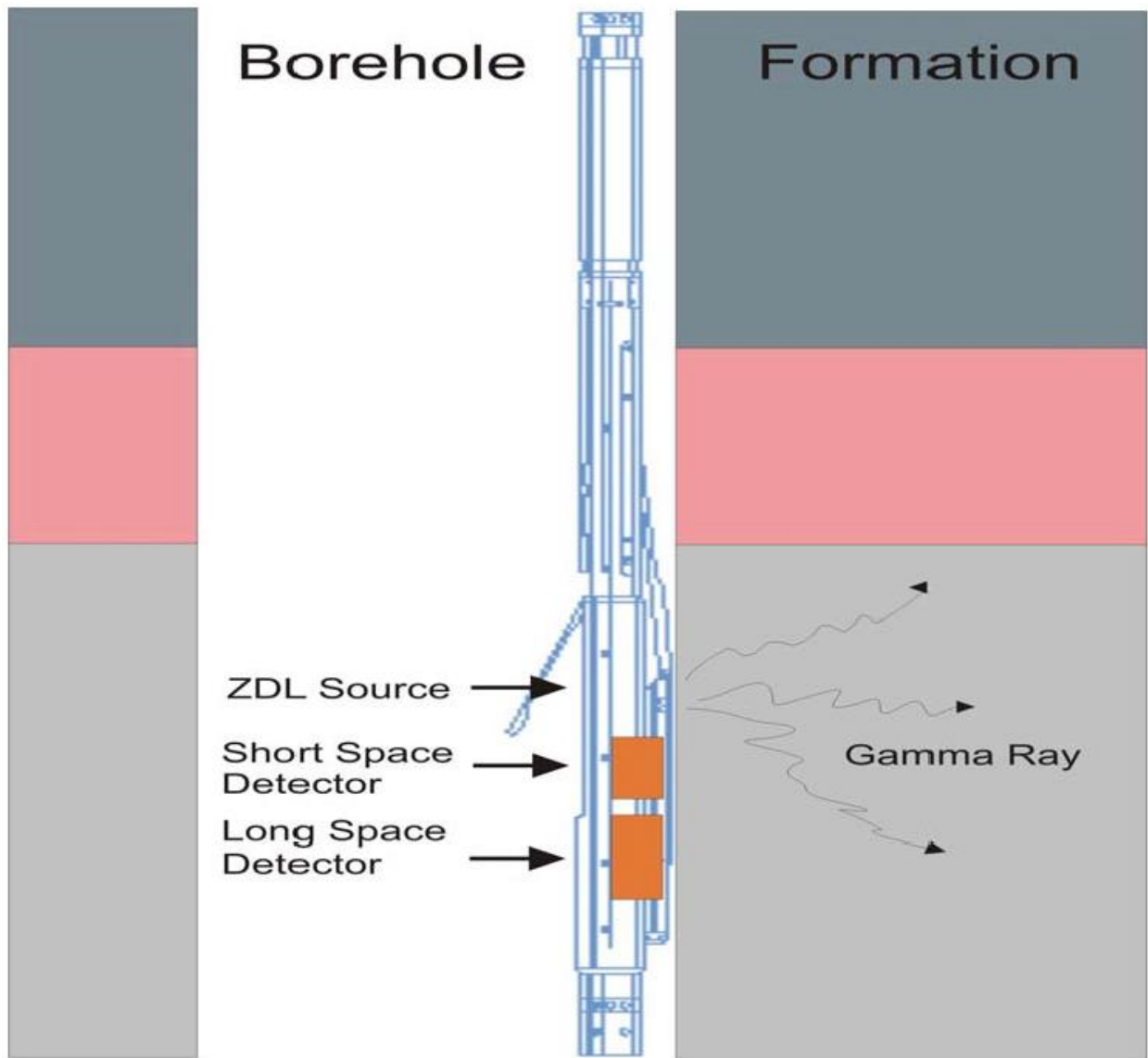

## TOOL CONFIGURATION

The density utilizes

- ✓ A Cesium 137 gamma ray source
- ✓ Two sodium iodide scintillation detectors
- ✓ Small Cesium 137 source near the detectors

All of which are mounted on an articulated pad.

The SS detectors count rates associated with Compton scattering used only in the determination of bulk density because it is covered by cadmium shield which absorbs all gamma rays of energy less than 140 KeV. The LS detector count rate depends on Compton scattering and photo electric effect used to determine both  $\delta_b$  and  $P_e$ . The LS detector is covered by beryllium shield absorbs gamma rays of energy less than 160 KeV.

## LIMITATION

- ✓ Primarily in open hole operation.
- ✓ Limited cased hole operation.
- ✓ Maximum hole diameter 22 inches.
- ✓ Minimum hole diameter 6 inches.

## Quick look Evaluation - Porosity

Density Evaluation technique

Porosity ( $\Phi$ ): Fraction of rock not occupied by solids

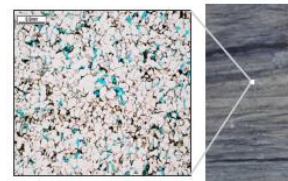
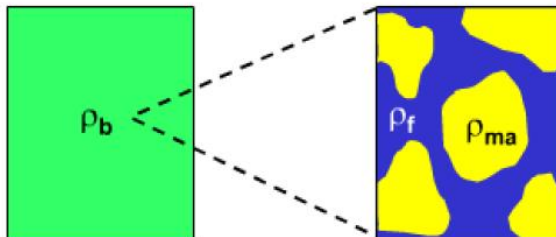

$$\rho_b = \rho_f \phi + \rho_{ma} (1 - \phi) \quad \rightarrow \quad \phi = \frac{\rho_{ma} - \rho_b}{\rho_{ma} - \rho_f}$$

where

$\rho_b$  = Density log reading

$\rho_f$  = Density of the saturating fluid

$\Phi$  = Porosity

$\rho_{ma}$  = Density of the matrix material

Typical density of common minerals/fluids

Quartz sand	2.65 g/cc
Calcite	2.71 g/cc
Shale	2.6-2.7 g/cc
Gas	0.3 g/cc
Oil	0.8 g/cc
Water	1.0 g/cc

## GAMMA RAY LOG

The standard gamma ray tool contains no source and it responds only to gamma ray emission from the downhole environment. Potassium (K40), Uranium (U238), Thorium (232) is the main radioactive materials. The main types of detectors are Geiger Muller detector or Scintillation Counters with NaI, CsI or BGO crystals (Photomultiplier, to measure incident gamma radiation). The detector is unshielded and will thus accept radiation from any direction.

### APPLICATION

- ✓ The gamma ray is particularly useful for defining shale beds when sp curve is rounded.
- ✓ It is used as a quantitative indicator of shale content.
- ✓ Detection and evaluation of radioactive minerals.
- ✓ Delineation of non-radioactive minerals including coal beds.
- ✓ Correlation in cased hole operations.
- ✓ The gamma ray log used in connection with radioactive tracer operation.

### GR - VSH Quick Look Evaluation

- ✓ Gamma Ray (GR) Evaluation Technique (Natural occurring radioactive elements in nature: K40-Potassium, Th232-Thorium, U238-Uranium)
- ✓ Spectral GR tool can discriminate between these elements, standard GR tool only provides the total GR counts

Reservoir rocks with low GR (Sandstone/Limestone/Dolomite). Shale has large amount of Th and K atoms and that's why high GR.

$$V_{sh} = \frac{GR - GR_{min}}{GR_{max} - GR_{min}}$$

$V_{sh}$  : Shale volume  
 GR : GR Log reading  
 $GR_{max}$  : GR Log reading in Shale zone  
 $GR_{min}$  : GR Log reading in clean Sand zone

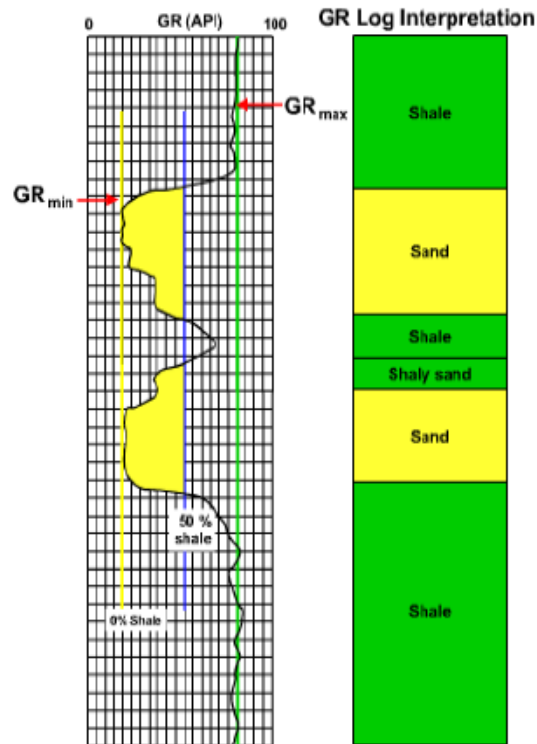

# DENSITY, $\gamma$ -RAY AND NEUTRON LOG

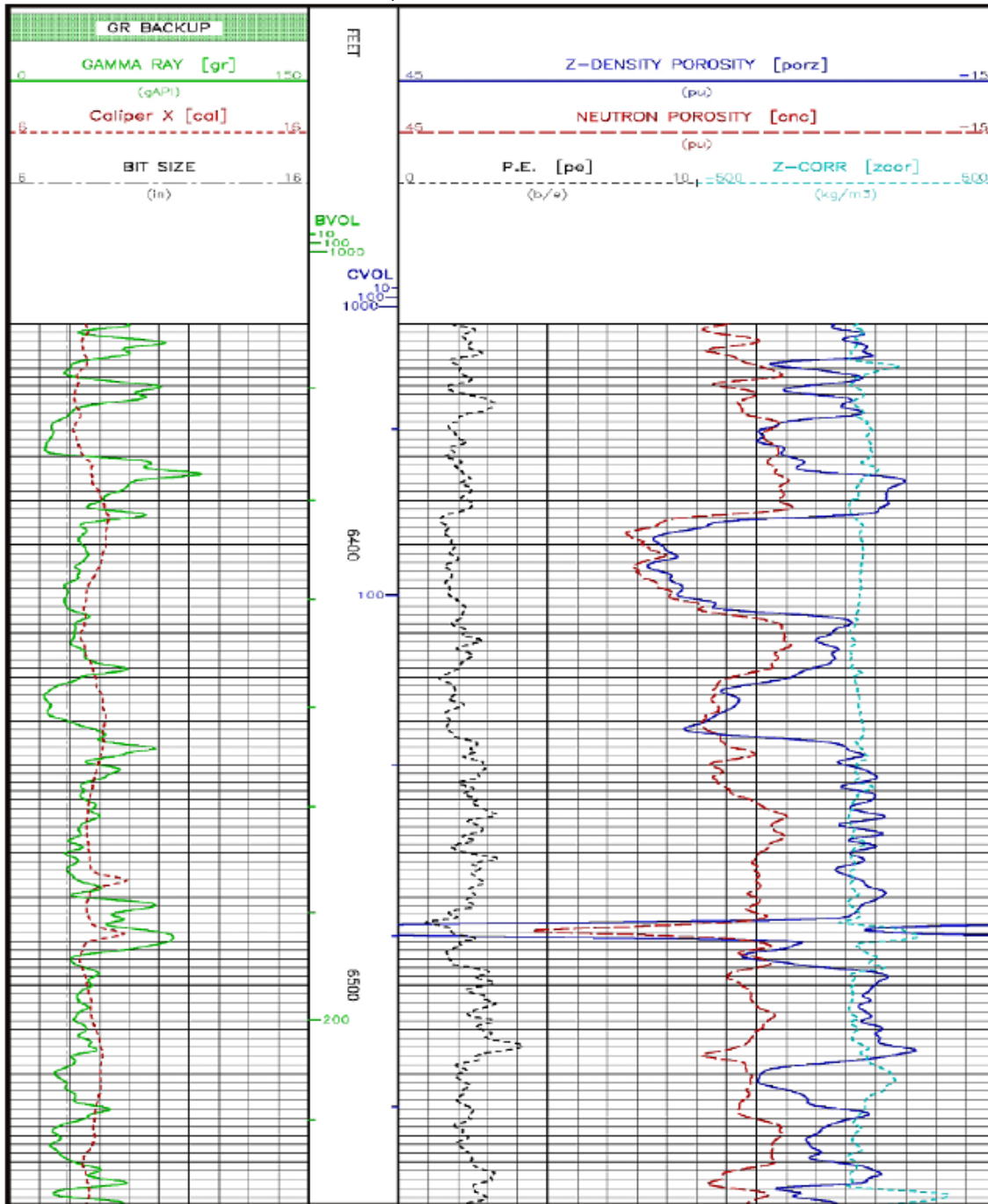



## SPONTANEOUS POTENTIAL LOG

### PRINCIPLE

SP arises due to salinity contrast between formation water and mud filtrate against permeable beds. No current is sent into the formation. The SP log is recorded by measuring the potential difference in milli-volts between an electrode in the borehole and a grounded electrode at the surface. The change in voltage through the well bore is caused by a build up of charge on the well bore walls. Shales and clays will generate one charge and permeable formations such as sandstone will generate an opposite one. This build up of charge in turn caused by differences in salt content and formation water.

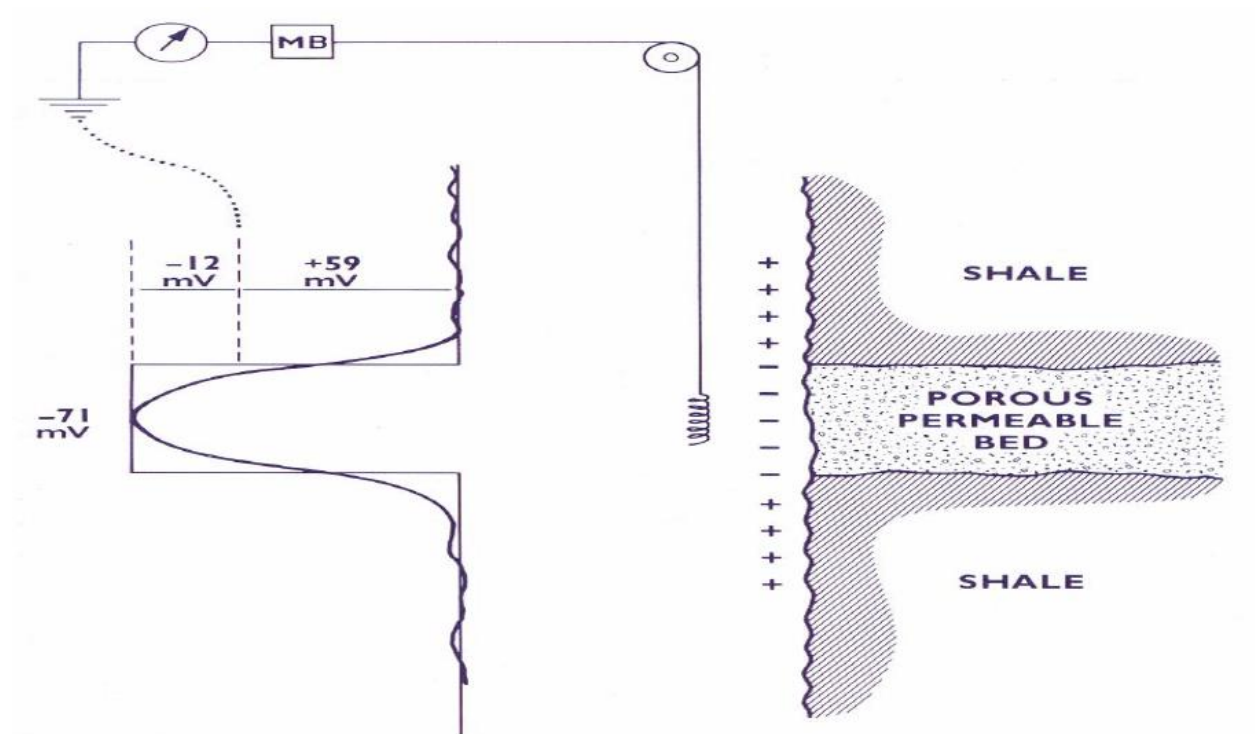

### A Schematic for measurement of SP

#### APPLICATION

- ✓ To delineate porous and permeable reservoir rocks
- ✓ To determine bed boundaries and bed thickness
- ✓ To evaluate the formation water resistivity
- ✓ To estimate the fraction of clay
- ✓ Correlation of permeable beds

## NMR Logging

Before a formation is logged by an NMR logging tool, the protons in the formation fluids are randomly oriented. When the tool passes through the formation, the tool generates magnetic fields that activate those Hydrogen protons.

First, the tool's permanent magnetic field aligns, or polarizes, the spin axes of the protons in a particular direction. This process, called polarization, increases exponentially in time with a time constant, designated as  $T_1$ .

Next, the tool's oscillating field is applied to tip these protons away from their new equilibrium position in the same way a child's spinning top *precesses* in the Earth's gravitational field. **Precession** occurs as a body rotating about one axis slowly rotates around a second axis. In the NMR case, this second axis is the static magnetic field. This is shown in figure below (*Spin precession*).

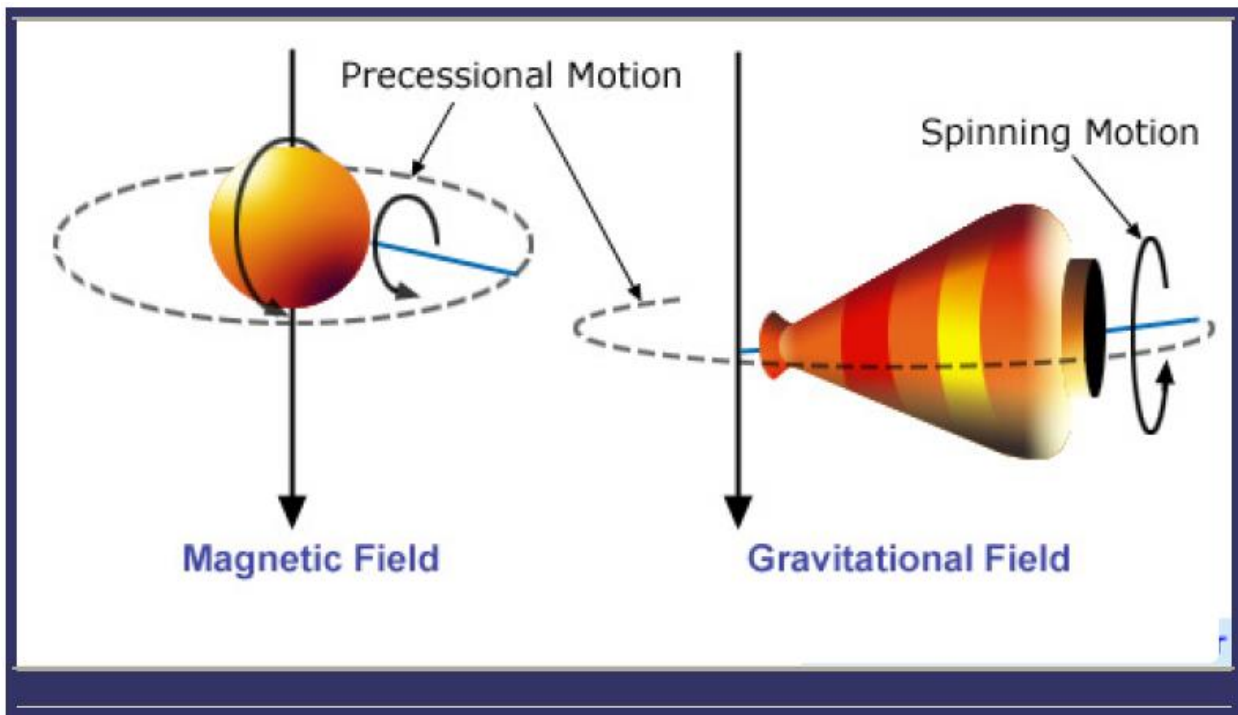

When the oscillating field is subsequently removed, the protons begin tipping back toward the original direction in which the static magnetic field aligned them. In NMR terminology, this tipping-back motion is called *relaxing*, and measurement of the '*relaxation time*' is the fundamental measurement of NMR logging tools.

## **APPLICATIONS**

- Total and Effective Porosity measurements without mineralogy effects
- Accurate Bulk Volume Irreducible/Free Fluid Index measurements
- Permeability determination
- Pore-size distribution
- Measurement of viscosity
- Hydrocarbon typing and quantification
- Accurately Identifies: Fluid contacts, By-passed pay zones, Low contrast/low resistivity pay zones

## **SIDEWALL CORING (SAMPLE TAKER)**

There are many methods of taking samples of formations during drilling of a well.

1. Cutting Cores with special angular bit.
2. Collecting and cutting from mud with logging stream.
3. Sidewall coring with logging cables.

## **ADVANTAGES OF SWC**

- ✓ Rig time saving
- ✓ Cost saving
- ✓ Exact depth control
- ✓ Quick handling of cores at surface
- ✓ Sampling of very soft formation also possible
- ✓ Sampling of any time before casing.

## **CASED HOLE LOGGING UNIT**

Cased hole logs are run to assess well integrity, improve reservoir management and scan the well for bypassed production before plugging and abandoning. It is extremely important in secondary & tertiary recovery programs. Cased hole logs can be placed into two categories:

### **Well bore integrity**

Evaluate cement sheath around the casing, mainly

- ✓ Cement top location.
- ✓ Fraction of annular fill.
- ✓ Cement compressive strength.
- ✓ Casing condition. (Depth & extent of damage).

### **Fluid movement**

This category detects channels behind pipe in both injection and production wells.

## **CASED HOLE OPERATIONS**

### **CASING COLLAR LOCATOR**

The CCL detects casing collars and perforations in tubing and casing.

### **DESCRIPTION**

The CCL is a magnetic device that detects changes in metal mass, such as those induced by the relatively high mass of a casing collar vis-a-vis (with regard to) the casing. The disturbance to the magnetic field is detected as a voltage difference. The CCL detects changes in metal volume as it moves through tubing or casing. The tool detector is comprised of a coil mounted between two opposing permanent magnets. As the tool passes a collar, the lines of magnetic flux between the magnets are disturbed, inducing a low frequency voltage in the coil. The signal is amplified and gated onto the wireline.

### **PURPOSE**

To determine the location of casing collars.

### **APPLICATIONS**

Depth correlation.

### **CEMENT BOND TOOL CEMENT & ISOLATION**

The main purpose of cement over the production interval is to provide isolation between neighboring zones. Failure in isolation can cause problems like water production, depletion of gas drive mechanism, loss of production to neighboring zones, contamination of fresh water sands etc. The remedy, is to squeeze cement job but it is not much benefit.

### **DESCRIPTION**

The CBT evaluates cement bond integrity. The tool typically has a single omni directional acoustic transmitter and two receivers. One receiver at three feet and another receiver at 5 feet. The tool has no azimuthal capability; instead the received signal is an average from all around the pipe.

### **PRINCIPLE**

The CBT measures based upon the principle of sonic wavetrain attenuation, detecting the amplitude of a sonic signal passing along the casing as an analog waveform. The signal is reduced where the casing is bonded to the cement, clearly identifying cement bond. The primary amplitude is detected at 3 feet receiver and variable density log is generated at 5 feet receiver.

### **PURPOSE**

Cement bond integrity is requisite to hydraulic isolation.

### **APPLICATIONS**

Cement bond evaluation.

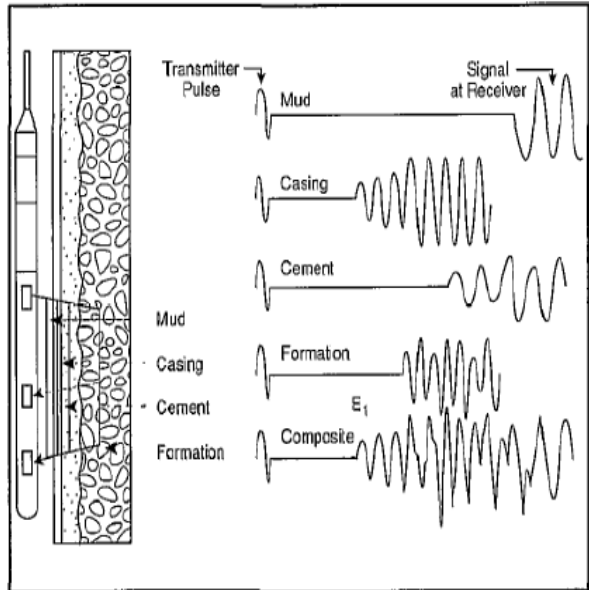
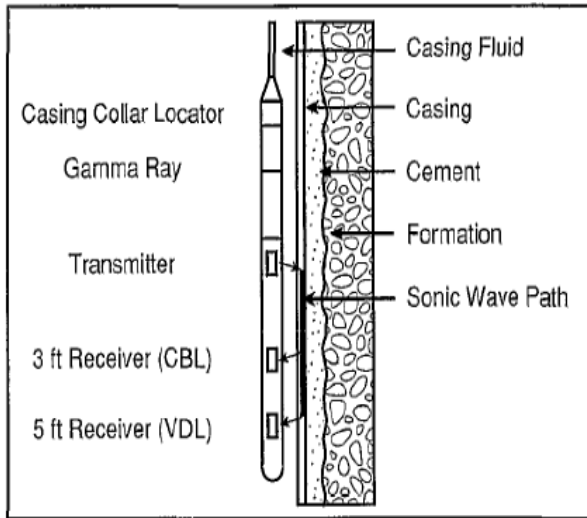

# Quick Look Evaluation - Lithology

- Quicklook Evaluation

  - Lithology
  - Volume of Shale
  - Porosity
  - Saturation
  - Net / Gross

Density / Neutron Combinations (Limestone compatible scale)

### Water-filled sands

- Density left of neutron porosity

### Oil-filled sands

- Density slightly lower than in water
- Neutron slightly lower than in water

### Gas-filled sands

- Density read lower than oil/water
- Neutron porosity low (low HI)

### Shale

- High neutron porosity (bound water)
- Slightly higher density than sands
- neutron plots left of density

### Calcites:

- high density, low neutron

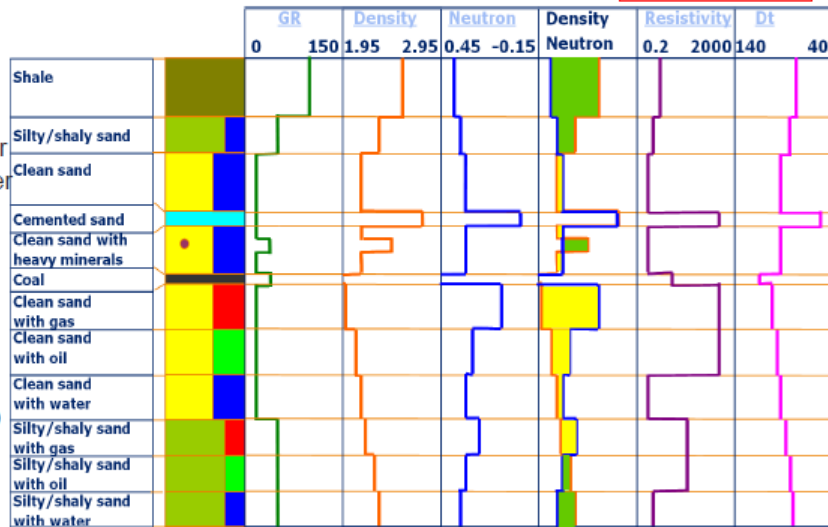

**Tool Positioning-Must run centralized**  
**THE CBL-VDL DATA FORMAT ACQUIRED**

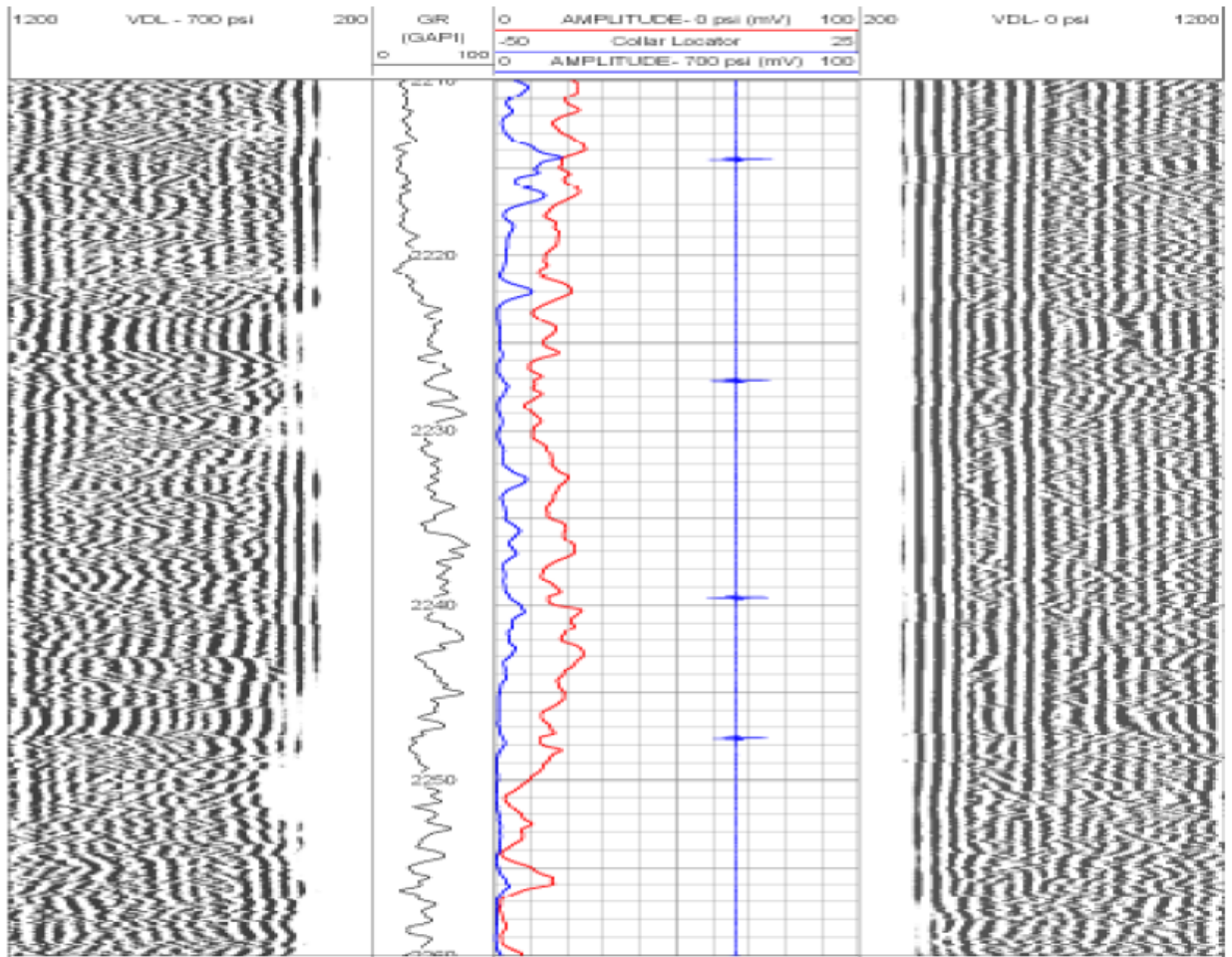

## PERFORATION

To establish fluid communication between well bore and formation for production / injection. It uses high explosives with shaped charges.

Perforators uses

- ✓ Initiator / detonator
- ✓ Detonating chord
- ✓ Shaped charges

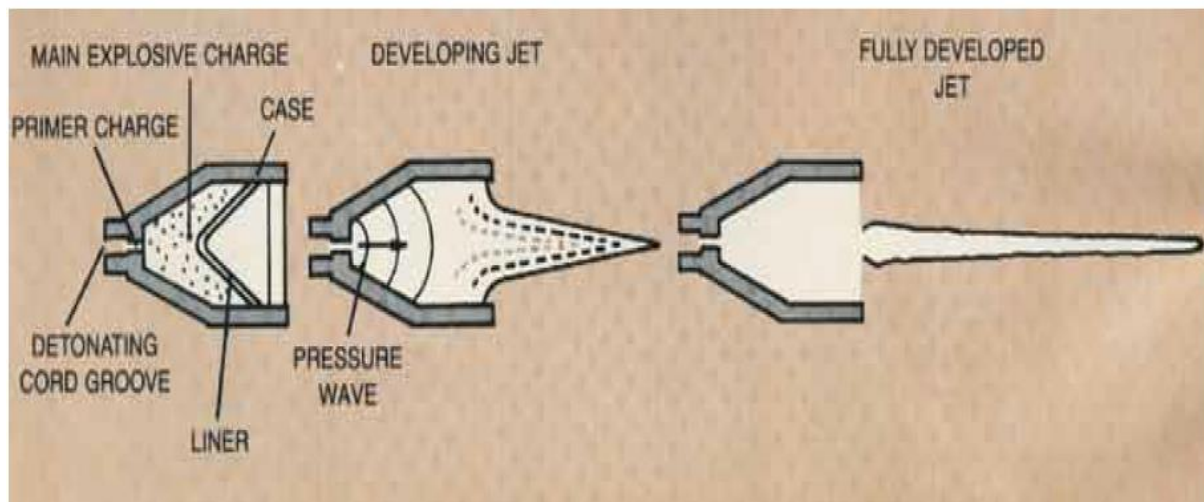
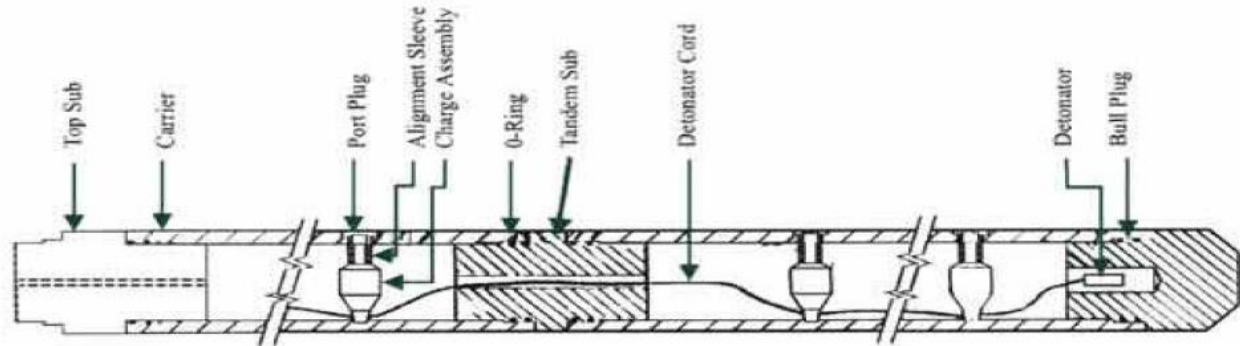

The two types of perforations are

**Over balanced method** (+Ve head).

**Under balanced method** (-Ve head).

The positive head is achieved by keeping higher density mud in the borehole as compared to formation pressure. The advantage is it is easy to handle the well during perforation.

The negative head is achieved by keeping lower density borehole fluid compared to formation. The advantage of the well is it can be straightway connected to the production pipeline. However caution is exercised to avoid blowouts.

## BRIDGE PLUG SETTING BY WIRE LINE

Bridge plug are mainly used for isolation o zones in casing. This prevent the movement of fluid from either direction.

### **Back off services**

Sometimes the drill string or tubing gets stuck in the bore hole. To release it a shock at a joint just above free point is given, when detonating cord is fired it release the string.

### **Puncture job**

It is a perforation operation with specially design small charge so as to have big holes with lesser depth of penetration.

### **PRODUCTION LOGGING**

- ✓ Production logging provides down hole measurements of fluid parameters on a zone
- ✓ Zone basis to yield information on the type of fluid movement within and near the well bore.
- ✓ Major application of production logging include
- ✓ Evaluating completion efficiency.
- ✓ Detecting mechanical problems, breakthrough, coning
- ✓ Monitoring and profiling of production and injection
- ✓ Detecting thief zones, channeled cement.
- ✓ Single layer and multilayer well test evaluation.
- ✓ Identifying reservoir boundaries for field development

### **RADIOACTIVE FLUID DENSITY TOOL PRINCIPLE**

The density tool responds to the electron density of the fluid in the bore-hole. It is used to differentiate the various types of fluids in the bore-hole depending upon their densities.

This tool measures borehole fluid density by radioactive technique. Part of the fluid flow passes through the tool between low activity Cs 137 gamma source and a Scintillation gamma ray detector. An increase in the average fluid density in the sample volume causes a reduction in received counts.

### **PURPOSE**

The purpose of the FDR is to measure fluid density of a sample as it flows through the tool. The average density of this volume is measured whether the flow is single or multiphase.

### **APPLICATIONS**

- ✓ Multiphase production drilling
- ✓ Fluid identification
- ✓ Horizontal /Highly deviated wells
- ✓ High fluid flow rates

### **PRODUCTION GAMMA RAY TOOL CONFIGURATION AND PRINCIPLE**

The production gamma ray tool comprises a sodium iodide scintillation crystal and photomultiplier to measure incident gamma radiation. The single conductor passing through the



tool carries telemetry and power. The detector is unshielded and will thus accept radiation from any direction.

#### **PURPOSE**

- ✓ Lithology identification
- ✓ Depth correlation
- ✓ Identification of radioactive scale, possible sign of water entry.
- ✓ Monitoring of radioactive flow tracer.
- ✓ Gravel pack density monitoring (with addition of gamma source).
- ✓ Evaluation of shale volume.
- ✓ Delineation of nonradioactive mineral including coal beds.

It can be run in both open and cased holes.

#### **CAPACITANCE TEMPERATURE FLOWMETER**

The sondex capacitance water hold up, temperature, flowmeter tool (CTF) provides these three basic Production logging measurements within a short tool length. In the case of standard tools the equivalent three sensors will be at least six times further apart and so in heterogeneous flow are less likely to be providing measurements within the same fluid simultaneously.

#### **PURPOSE**

To provide a continuous log of fluid capacitance (water hold up), Temperature, Flowrate and flow direction.

#### **APPLICATION**

- ✓ Fluid composition from average dielectric constant.
- ✓ Fluid ID from temperature response.
- ✓ Location of leaks and crossflow by temperature response.
- ✓ Quantitative measurement of flowrate in casing and tubing.
- ✓ Production and injection log interpretation.
- ✓ Cement top determination.

#### **ENHANCED CAPACITANCE WATER HOLD-UP TOOL (CWH)**

Halliburton's Enhanced Capacitance Water Hold-Up Tool (CWH) measures the dielectric constant of the surrounding borehole fluid to determine the water holdup. Its improved response characteristics provide two phase production profiling, oil/water hold-up calculations, and accurate analysis of high GOR wells. In addition, with its ability to simultaneously operate with other Halliburton production logging tools, the CWH fits effortlessly into an operator's catalog of resources.

Borehole fluid enters a hollow tube that surrounds an insulated rod at the center. The tube wall and the insulated rod form the electrodes of a capacitor. As hydrocarbons and water have different dielectric constants, the capacitance is a function of the dielectric constant of the fluid between the rod and wall of the tube. This capacitance is incorporated in the frequency determining circuitry of an oscillator. The frequency of the oscillator is therefore a function of the type of fluid that is present in the borehole.

The dielectric constant of water is 80, oil is around 10, and air has a value of 1. Salinity has minimal effect on tool measurement. The enhanced measurement has improved response characteristics particularly at water holdup values greater than 50%. The improved design also minimizes the “watering out” effect that can, under certain circumstances, result in the tool continuing to read water even though the surrounding fluid has been replaced by hydrocarbons.

**BENEFITS**

- ✓ Provides accurate capacitance measurements compared to earlier generation capacitance tools
- ✓ Accurate water holdup measurements

**FEATURES**

- ✓ Tool design helps reduce problems in high water cut wells
- ✓ Fully combinable with all Ultrawire™ production logging tools
- ✓ Surface read out or memory logging operations



<b>Enhanced Capacitance Water Hold-Up Tool (CWH)</b>	
Temperature Rating	350°F (177°C)
Pressure Rating	15,000 psi (103 MPa)
Tool Diameter	1-11/16 in (43 mm)
Tool Length	26.2 in (666 mm)
Tool Weight	9.5 lb (4.3 kg)
Supply Voltage	+18 V DC (nom)
Current Consumption	17 mA
Telemetry	Ultrawire™
Accuracy	1.0% (approx.)
Resolution	0.1%
Acquisition Time	1 sec (typ)
Effective Range	0-40% Water-cut

PALZ 6528

## **CALIPER LOG**

It is used to measure the variation of borehole diameter with depth. Caliperlog presents the bore hole cross-sectional variation.

## **CLASSIFICATION**

All borehole calipers use arm, fingers, or pads which act as sensor feeder and remain in contact continuously with borehole wall during the recording of the log in borehole. It is classified as single arm or pad calipers and two, three or four arm springs calipers.

## **APPLICATIONS**

- ✓ High-resolution lithology discrimination.
- ✓ Depth calibration of different log suites.
- ✓ Fracture identification.
- ✓ Measurement of borehole rugosity.
- ✓ Estimation of mudcake thickness. The information is used to correct the micro resistivity log readings.
- ✓ The evaluation of temperature and CBL logs in combination with caliper data help to diagnose quality of cementation.

### **Determination of the productivity of the well. This involves:**

- ✓ Determination of mobility.
- ✓ Calculation of permeability.
- ✓ Determination of formation pressure.
- ✓ Determination of the lithology, facies and depositional environment to get an idea of reservoir geometry as well as petrophysical properties of the reservoir.
- ✓ Exact nature (number & type) of the principal minerals and if possible, of the accessory ones, since any error in mineral type can lead to significant errors in calculation of porosity, of saturation and of reserves.
- ✓ Percentage of the principal minerals.
- ✓ Percentage of clay, clay type & distribution.
- ✓ Estimation of texture, grain size distribution, sorting and grain shape.

### **LITHOLOGY IDENTIFICATION:**

Porosity determination using different logging devices relies on the knowledge of the rock type. In the case of the density tool, the density of the rock matrix must be known. The matrix travel time must be known to determine porosity from sonic log. In order to get porosity from neutron log the matrix setting for the neutron tool must correspond to the rock type. Determining these parameters is not much of a problem if one has good geological knowledge of the formation or if the lithologies encountered are simple, such as, for instance clean sandstone formation. If opposite is the case, if one is not sure about lithology, the best way will be to adopt graphical methods.

### **OVERLAY OF POROSITY LOGS ON A COMMON REFERENCE SCALE:**

The three types of porosity log, which are available (sonic, density, neutron), are recorded in drastically different units (microseconds per foot, grams per cubic centimeter, and neutron counts in  $v/v$  or percentage porosity unit). However, the logs can be directly compared if calibrated on a common reference scale. The most widely used scale for this purpose is defined in terms of equivalent units of limestone percentage porosity. The density scale may be transformed by setting the grain density of calcite (2.71 g/cc) to zero porosity, the fluid density (1.00 g/cc for fresh water) to 100% porosity and interpolating intermediate values. By an analogous procedure the transit time of the sonic log can be converted to the limestone porosity equivalents by setting the matrix transit times of calcite & pore fluid as the two porosity extremes for interpolation. Limestone porosity scale is the most common reference of the neutron logs and hence requires no scaling.

An overlay of any combination of the three porosity will give immediate indications of the lithology of logged units by virtue of the different responses of matrix minerals to the individual porosity logs. This point is illustrated by comparing the hypothetical response of a mixed sequence of lithologies to the density & neutron logs.

In log interpretation the main focus is to identify the formations susceptible of containing displaceable fluid. These formations are porous and permeable formations. Once the porous and permeable formations have been identified, the next great thing to do is to determine the nature of the fluid content in the pores. The fluid can be water or hydrocarbon, with rare instances of gases like nitrogen or carbon dioxide being present.

G.E. Archie's work relating permeability to porosity resulted in empirical relationships between resistivities, fluid types and porosity. In undisturbed formations, Archie's (empirical) law states that the ratio of formation resistivity to connate water resistivity ( $R_o/R_w$ ) is constant. That is

$F=R_o/R_w$  (eqn1) Where:

- ✓ F is called the formation factor,
- ✓  $R_o$  is bulk resistivity if pore space is filled 100% with brine (connate water),
- ✓  $R_w$  is resistivity of the connate water itself. This relation applies best for clean (clay free) rocks of constant porosity when  $R_w < 1$  Ohm-m, at 25C.

This is useful, except that  $R_o$  is not really measurable in the field. But the relation can be made useful because Archie also found that this resistivity ratio (i.e. F) changes consistently as porosity changes.

- ✓ Formation factor and porosity are usually related via
- ✓  $F=a / \phi^m$  (eqn 2)
- ✓ where  $\phi$  is porosity expressed as a percent (a value between 0 and 1).
- ✓ **a** is a constant between 0.6 and 1.5. It is often left at 1.
- ✓ **m** is the cementation exponent and is usually 1.5-1.8 in sandstones and 2.0 in limestones, dolomites and tight consolidated sandstones.
- ✓ One example of a particular version is  $F = 0.62/ \phi^{2.15}$  ( the so-called "Humble relation", suitable for many granular rocks).

AN ALTERNATIVE RELATION IS:

- ✓  $F = 1/ \phi^{(1.87+0.019/\phi)}$  (The Shell relation, best used for low-porosity carbonates).

Finally, water saturation ( $S_w$ ) and formation resistivity were also found to be related. Water saturation is the percentage of the pore space filled with water, which is of course important when evaluating a potential hydrocarbon reservoir.  $S_w=1$  means all fluids are water 100% and  $S_w=0.1$  means 10% of fluids are water, implying 90% are non-conductive or oil/gas. The relation is  $S_w = (R_o/R_T)^{1/n}$  (eqn 3) where

- ✓ **n** is a saturation exponent, usually close to 2.0. (**n** is not porosity in this relation),
- ✓ **R<sub>o</sub>** = rock resistivity with 100% brine for fluid
- ✓ **R<sub>t</sub>** = true resistivity (with hydrocarbons and water in pore space).

Now the Archi equation relating quantities of interest to measurable quantities can be derived based upon eqns 1, 2, 3:

$$S_w = (FR_w/R_T)^{1/n} \text{ (eqn 4)}$$

This relation is commonly used for oil / gas reservoir characterization. Three parameters must be measured: (i) porosity, (ii) resistivity of the undisturbed formation, and (iii) resistivity of connate water. Symbols are  $\phi$ ,  $R_t$  and  $R_w$  respectively.  $R_w$  can be obtained from:

- ✓ Water catalogues of the area you're working in;
- ✓ Laboratory analysis of samples extracted from the formation rocks;
- ✓ Obtainable from the spontaneous potential or SP log;
- ✓ "Apparent" water resistivity from  $R_t = F * R_{wa}$  when  $S_w = 1$ , e.g. in "clean water sands";
- ✓ By relating invaded & uninvaded resistivity in **clean zones**;
- ✓ From resistivity - porosity crossplots;
- ✓ From  $R_{wa}$  - SP crossplots.

$R_t$  is true resistivity of undisturbed formation. Of course drilling disturbs the formation, so choosing the right tool and interpreting various resistivities is important. Methods must account for bore hole environment, invasion, effects of adjacent beds, and technical aspects of tools themselves.

In the oil / gas context, porosity  $\phi$  is obtained from the porosity well logging tools, or possibly from resistivity where  $S_w$  is known to be 100%. Porosity logging tools are also used in hydrogeology and engineering situations, though this is not routine as in the oil / gas industry.

**Exercise 1 (Identify the Sands. Determine the position of the sands, and the cumulative sand thickness. Use a 50% cut-off value for the GR reading between the shale and the cleanest sand).**

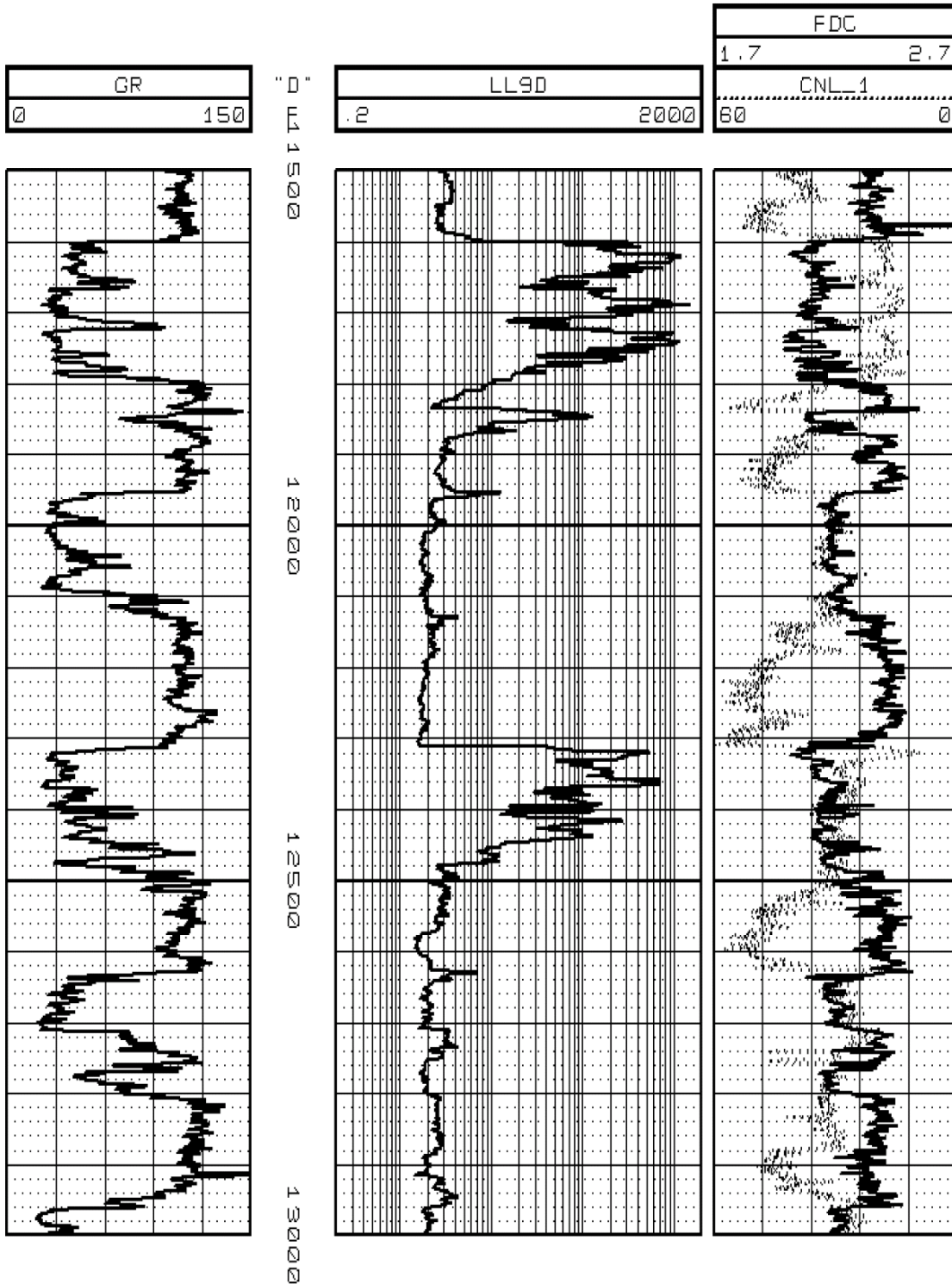

**Exercise 2**

Calculate the Porosity @ 12440' and 13000' (if oil density is 0.9 g/cc and water density is 1 g/cc).

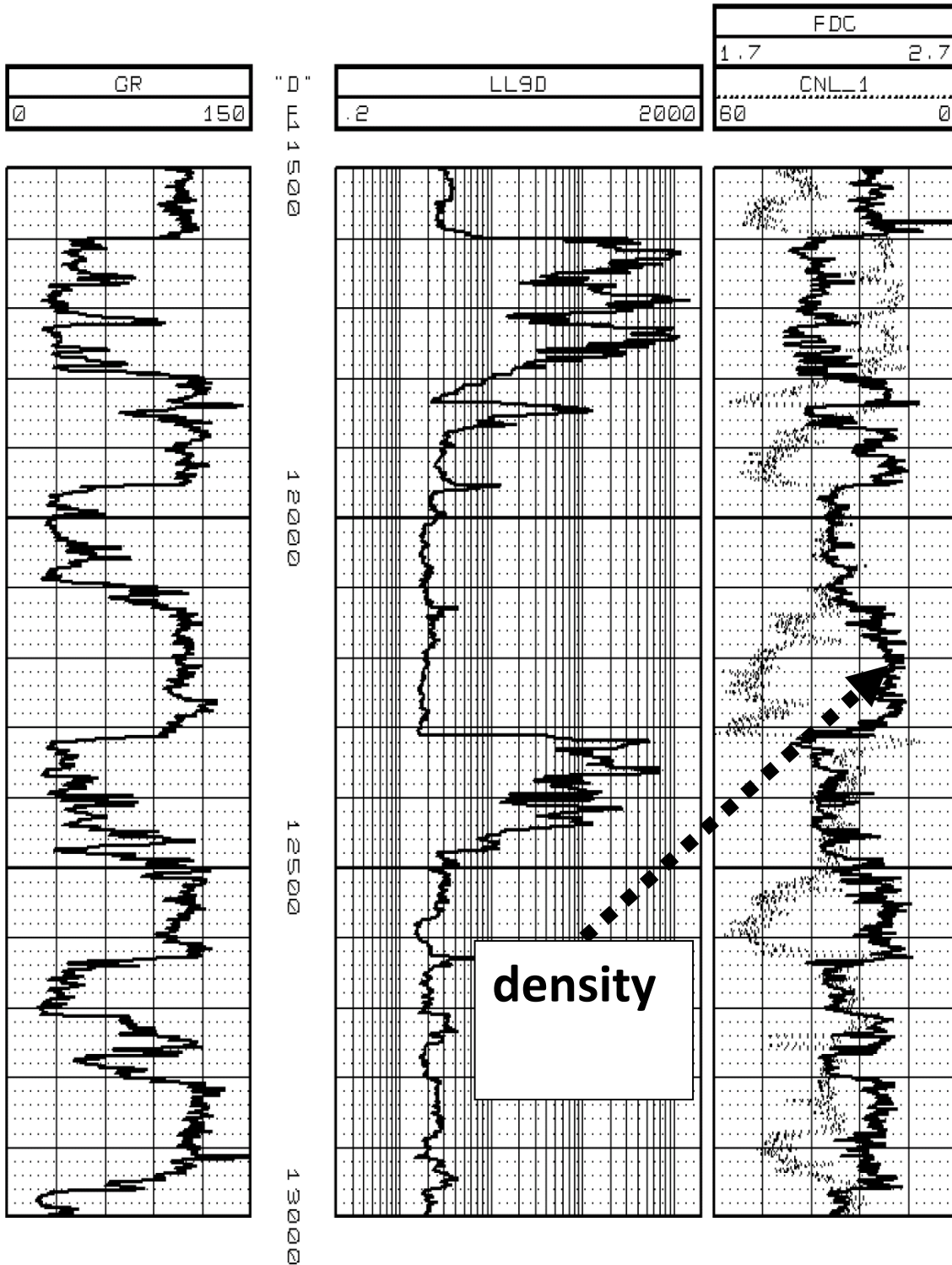



Exercise 3 Calculate apparent water resistivity  $R_w$  @ 13000' assume  $m=2$

Exercise 4 Calculate water saturation  $S_w$  @ 12440' use  $R_w$  from exercise 3 assume  $m=n=2$ , remember this is an oil zone  $\rho_{oil}=0.9$  g/cc

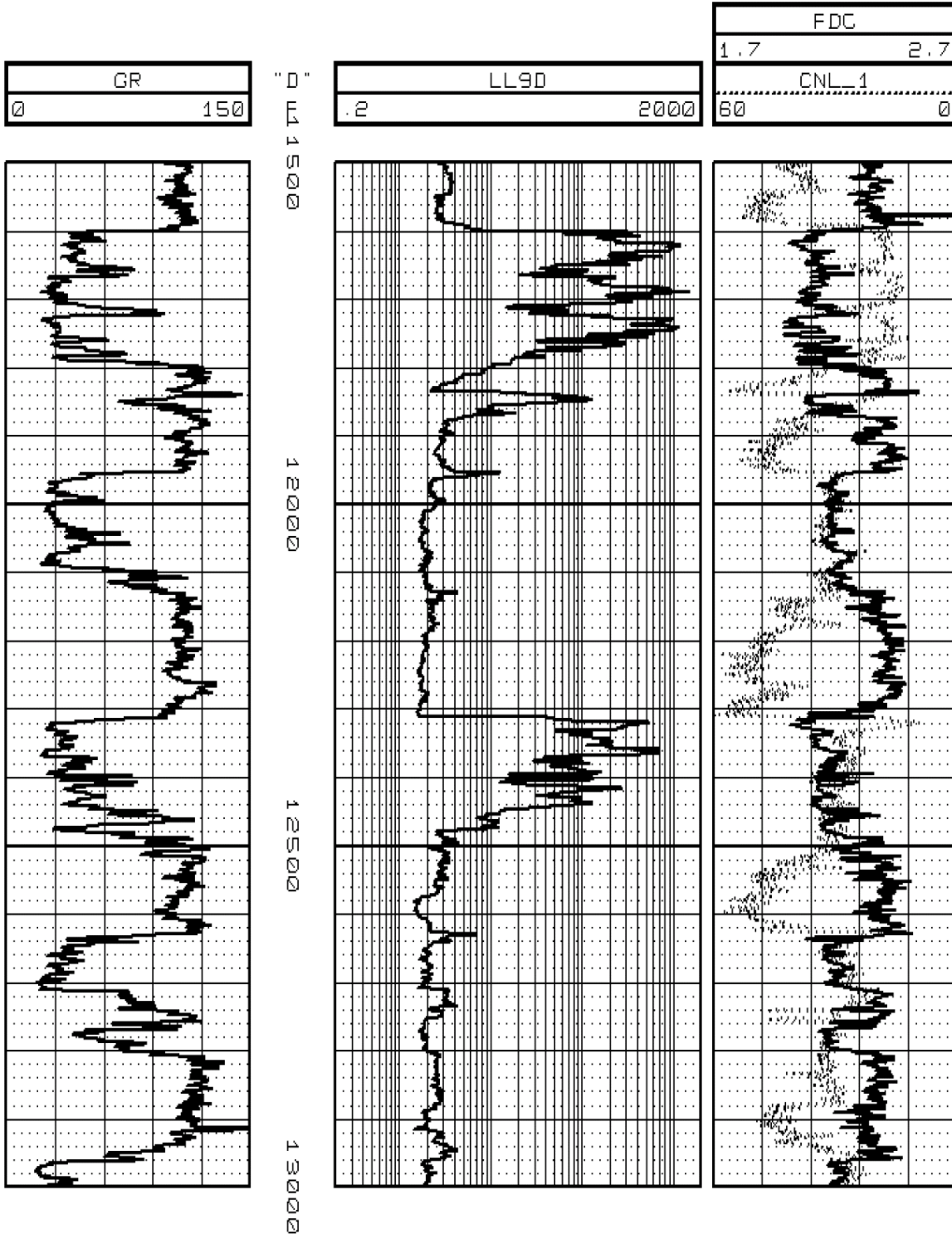

Answer of Exercise 1 (Net/Gross – Sands From Gamma-Ray (Nett=600 ft, Gross=1500 ft : N/G=40%).

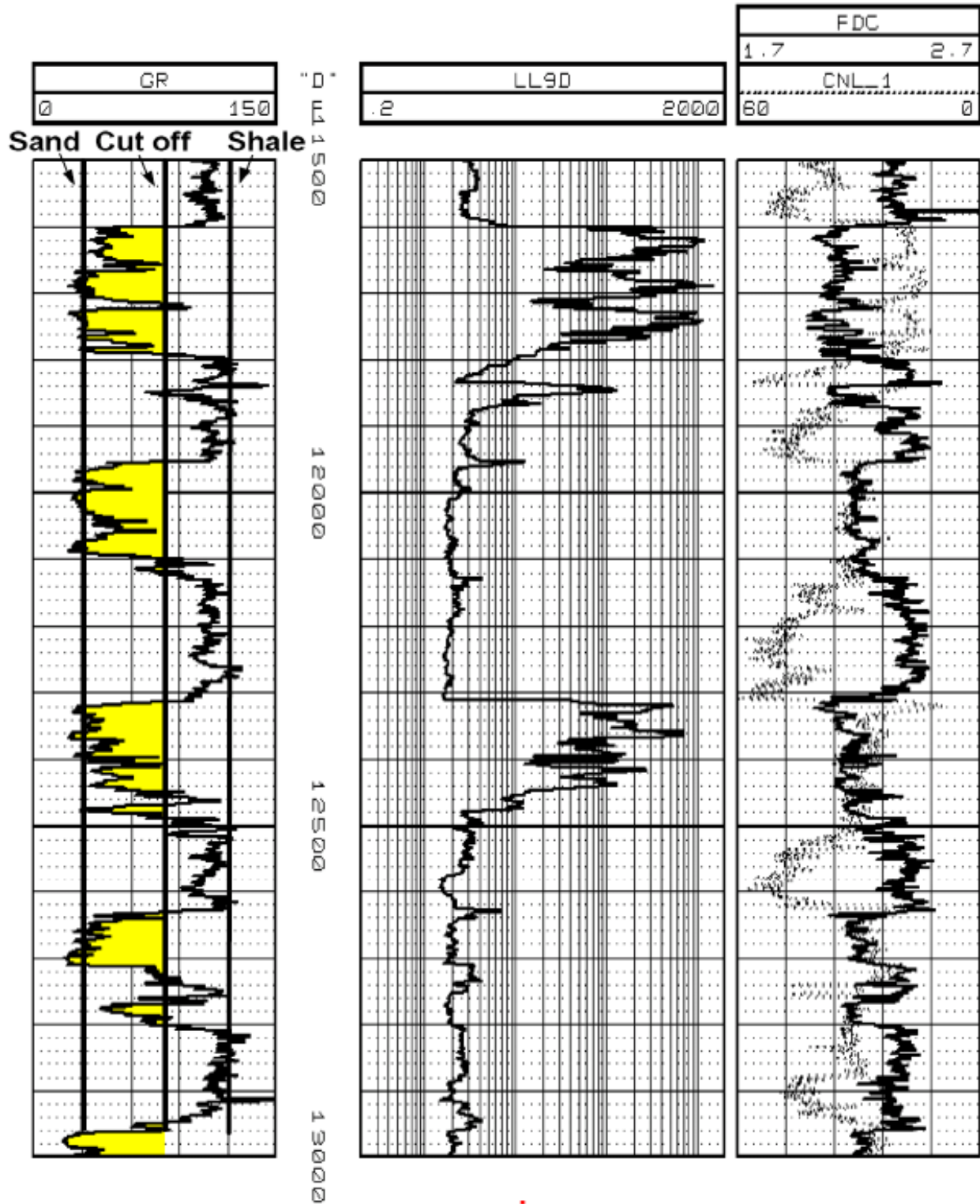

Answer of Exercise 2

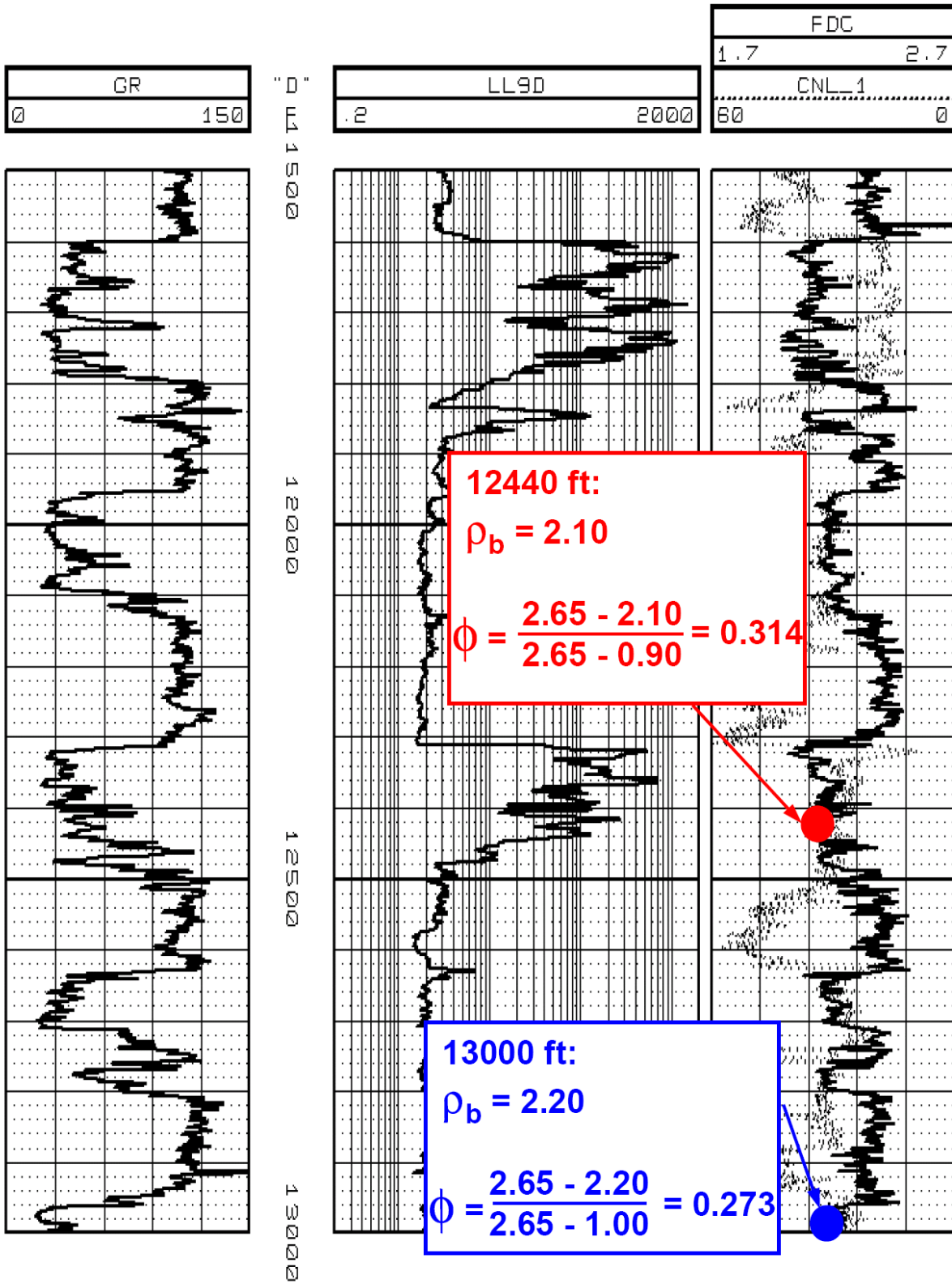

Answer of Exercise 3 (Calculate apparent, water resistivity  $R_w$  @ 13000'). Answer:  $R_w=0.149$  Ohmm

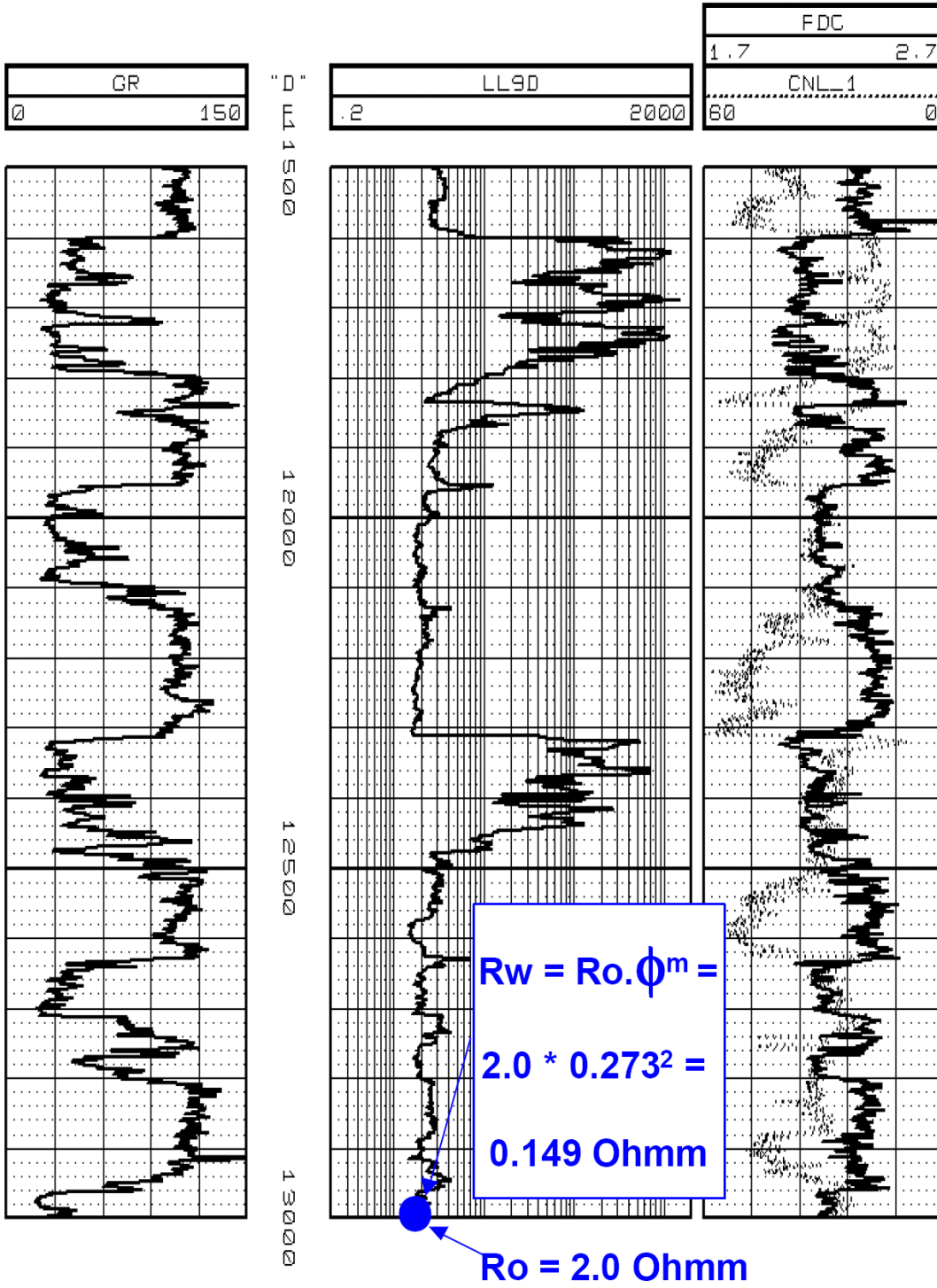

exercise

Answer of Exercise 4 (Calculate water saturation  $S_w$  @ 12440' use  $R_w$  from exercise 3, assume  $m=n=2$ )

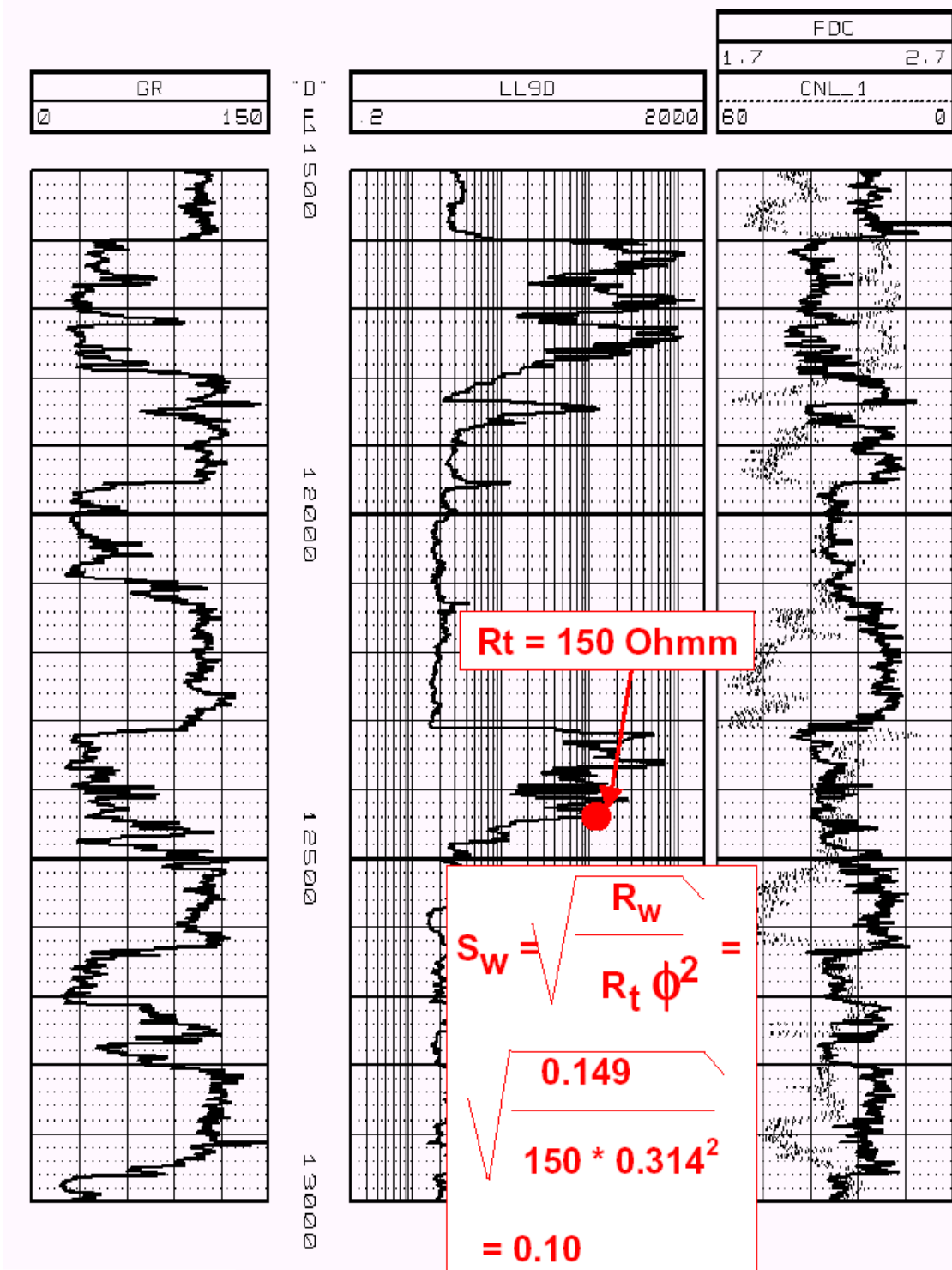

exercise

Identify fluids (Gas, Oil and Water)

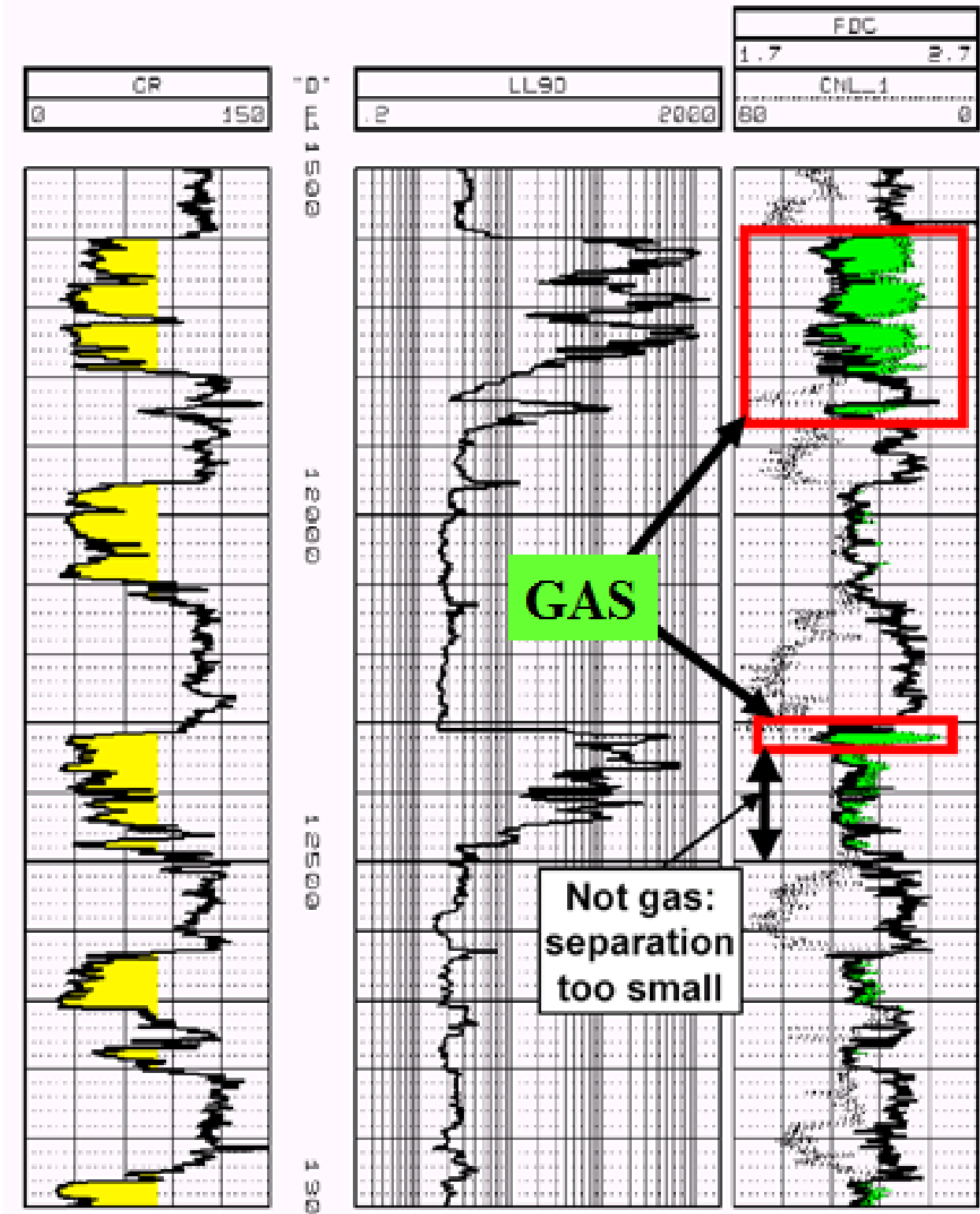

# Fluid Contacts

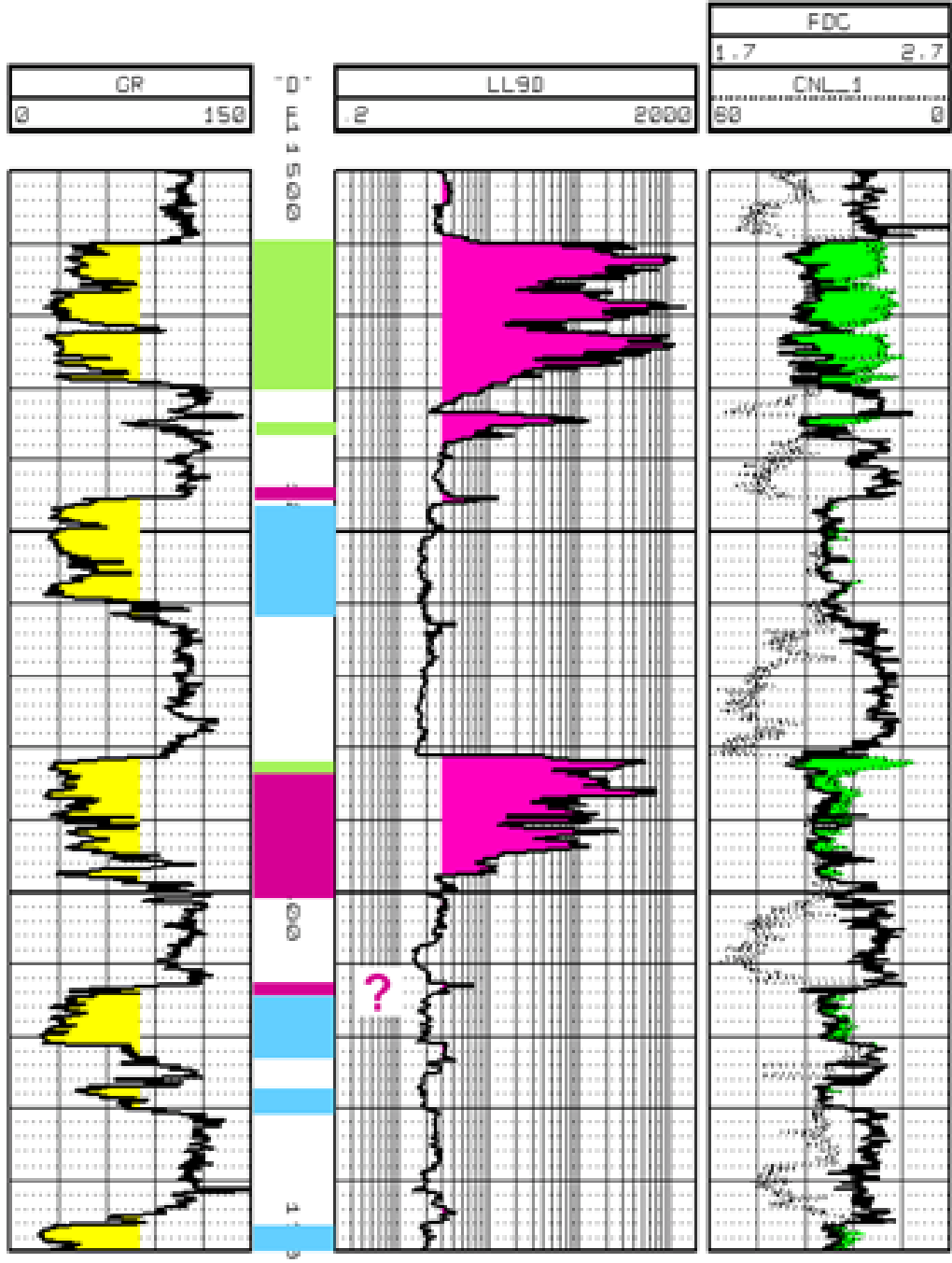

- Hydrocarbons  
neutron density  
separation
- gas
- oil
- water

## **LWD Sensors**

Logging while drilling (LWD) sensors can be differentiated in terms of use, measurement, depth of investigation and operational considerations.

### **LWD Sensor Categories**

LWD sensors can be categorized as either formation evaluation sensors or drilling efficiency sensors.

Formation evaluation sensors include:

- ✓ Lithology sensors
- ✓ Resistivity sensors
- ✓ Porosity sensors

**Lithology sensors** include gamma (DGR) and caliper (ACAL). The DGR sensor measures the natural formation radioactivity. It is used to provide lithological identification, to delineate bed boundaries, to evaluate the degree of shaliness of a formation and to identify geological markers. The ACAL sensor provides an accurate measurement of borehole diameter and ellipticity, plus BHA dynamics information, during the drilling process.

**Resistivity sensors** include EWR Phase 4 and Slim Phase 4. EWR stands for electromagnetic wave resistivity. The EWR-PHASE 4 and Slim Phase 4 sensors measure the resistivity of the formation. Resistivity is used to assist in calculating formation pore pressure, to measure the thickness of reservoir bed boundaries, to identify hydrocarbons in a formation, and to identify movable fluids.

**Porosity sensors** include density (SLD), neutron (CNP and CTN), and sonic (BAT). The CNP measures the hydrogen content of a formation. The SLD sensor measures the electron density of a formation. The CNP sensor, when run in conjunction with SLD, is used to identify gas-filled formations and to determine the porosity in liquid-filled formations, i.e., a formation filled with oil and water.

The CTN sensor can be combined with the Slim Phase 4, DGR, SLD, and PWD sensors to provide triple combo logging services in slim holes. The BAT sensor is used to measure porosity, seismic time-depth correlation, and pore pressure.

Drilling Efficiency sensors include:

- ✓ PWD
- ✓ DDS
- ✓ WOB/TOB
- ✓ ACAL

## **Lithology Sensors**

### **Dual Gamma Ray (DGR)**

The gamma tool measures naturally occurring gamma rays emitted from radioactive potassium, thorium and uranium. These three elements account for most of the radiation in sedimentary formations.

Shales have a large amount of potassium in them; therefore, a gamma tool reads high counts in shales. A shale baseline can be established throughout the shale intervals to provide a reference for gamma ray readings in other formation types.



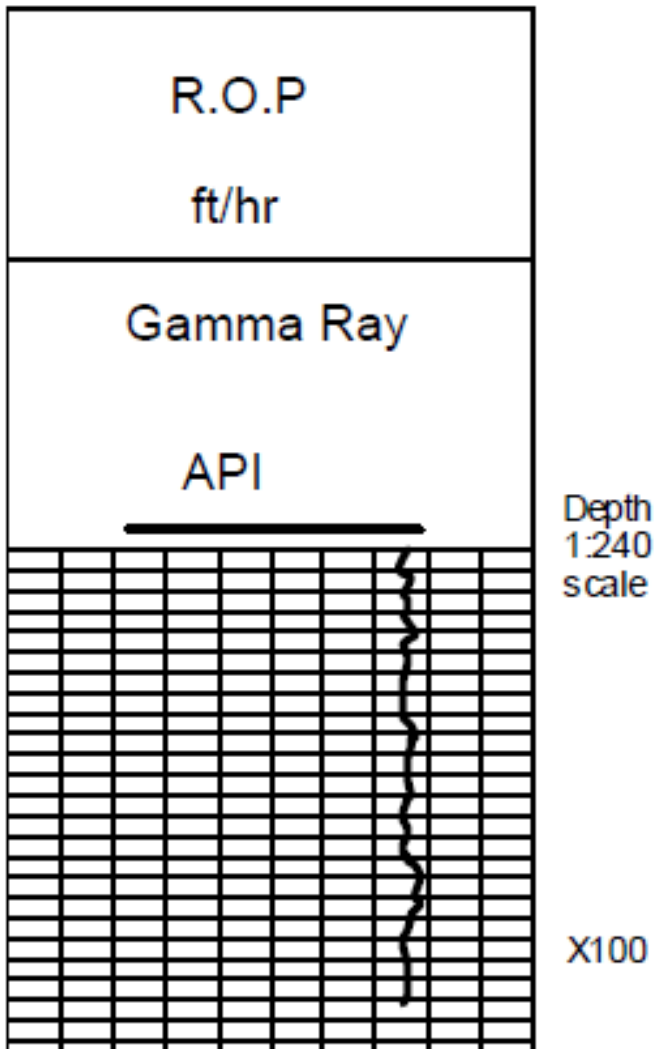

DGR Response in Shale

Sands, on the other hand, are relatively free of potassium, thorium, and uranium; therefore, a gamma tool reads low counts in sand. The curve should move to the left of the shale baseline. The magnitude of this shift will depend upon the percentage of shale present in the sandstone. The fluid content of the sandstone, whether it be gas, oil, or water, will NOT affect the response of the gamma sensor.

The only exception is the occurrence of precipitated uranium in the formation pore space which will cause the gamma ray response to be very high (much greater than the shale baseline) in the sandstone interval.

Crystalline salt does not contain naturally occurring radioactive elements. Therefore, the gamma response in a salt dome or salt stringer will be extremely low (0 - 10 AAPI units). Encountering salt will cause the curve to move to the left of even the cleanest sandstone interval.

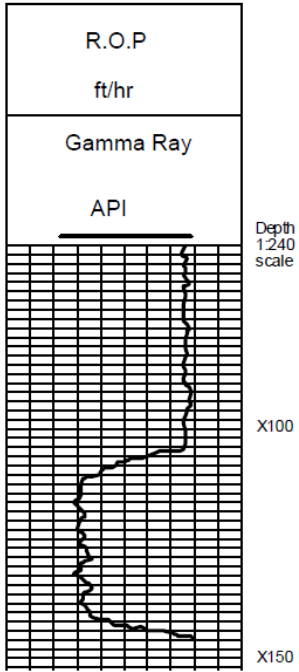

DGR Response in Sand

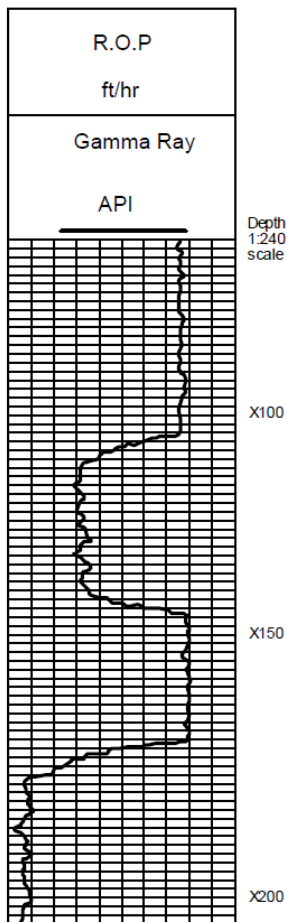

DGR Response in Salt

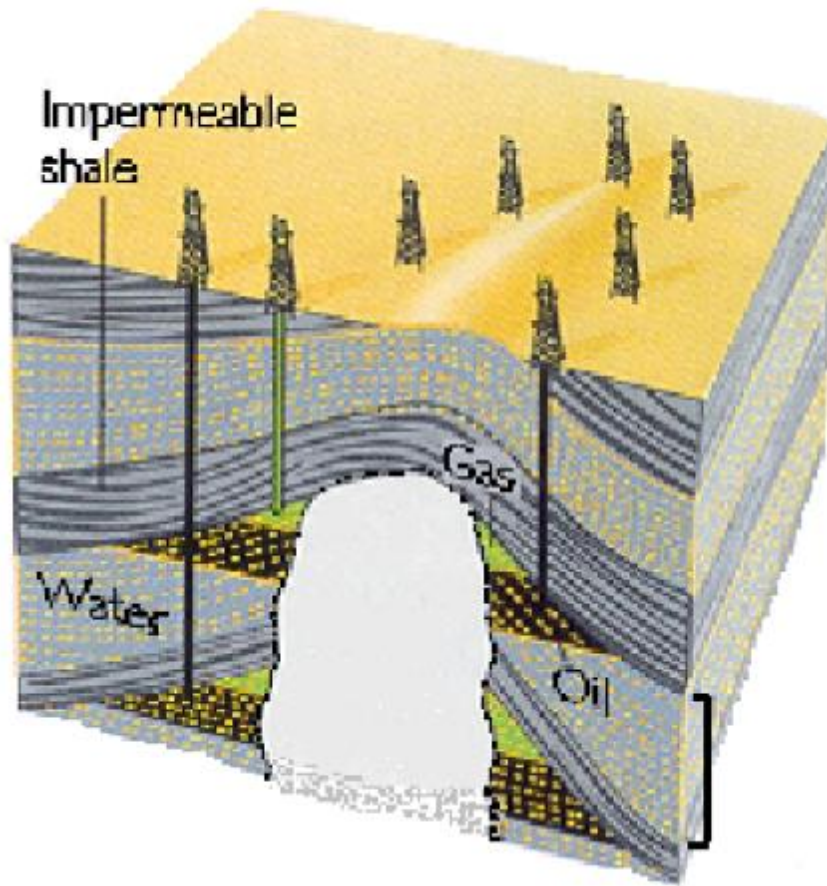

Salt dome

The Dual Gamma-Ray (DGR) sensor is made up of two opposed banks of Geiger-Muller tubes with two independent detector circuits. This redundant configuration provides two independent natural gamma ray curves. In real-time mode, the count rates from the two detector banks are typically combined to optimize statistical precision. However, in the unusual event of a failure of one detector bank, a corrected gamma ray curve can be produced from the second detector bank. When recovering recorded data after a bit trip, the two banks can be compared as a validity check. The DGR sensor is available in 4-3/4 inch, 6-3/4 inch, 8 inch, and 9-1/2 inch tool sizes.

For geosteering in horizontal wells, the DGR sensor can be configured to provide azimuthal gamma ray measurements. In this application, the two opposed DGR sensor detector banks can provide independent gamma ray curves from the high side and low side of the borehole. This can, for example, allow the operator to determine if the bit has exited the top or the bottom of a target reservoir formation.

The DGR tool is generally run in conjunction with porosity and resistivity tools.

## DGR Tool

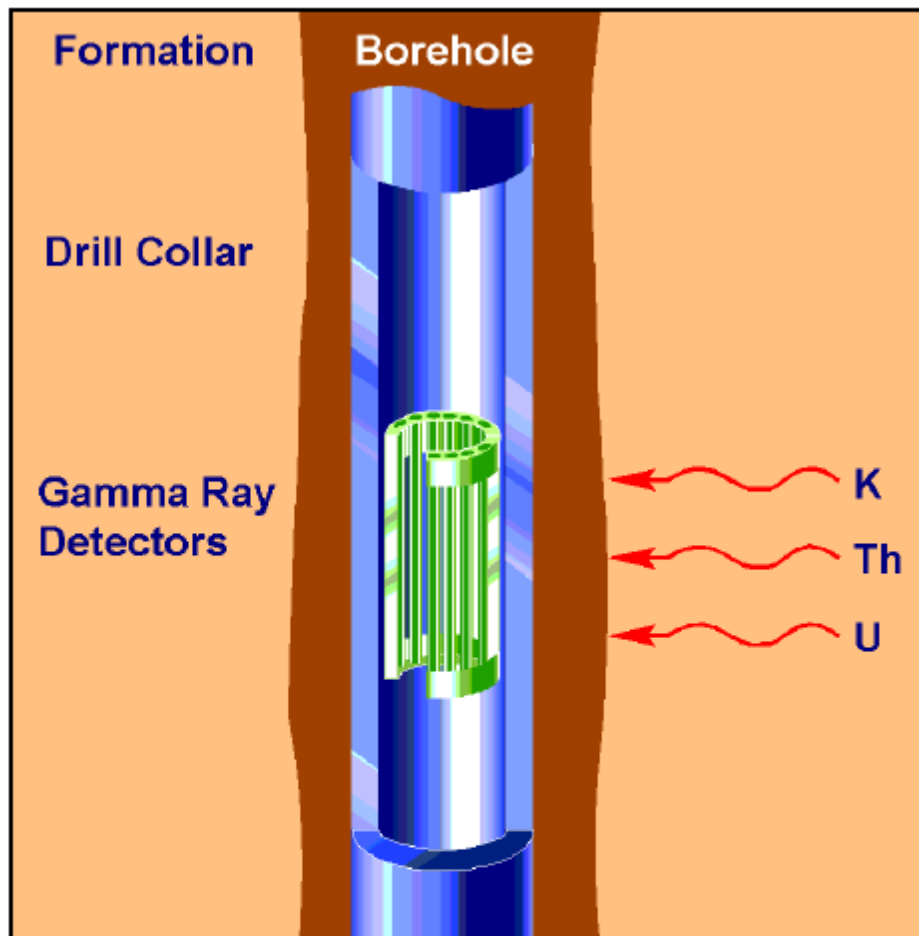

## Dual Detectors



## AcoustiCaliper (ACAL)

The AcoustiCaliper MWD tool is used to improve drilling efficiency by providing real-time borehole diameter measurements. This allows improved ECD calculations, borehole stability, directional control, and BHA dynamics.

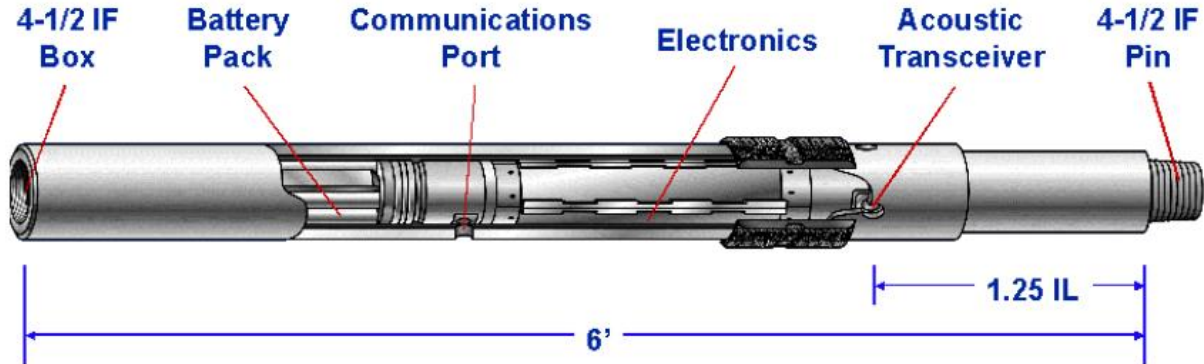

The AcoustiCaliper tool uses three ultrasonic transceivers (spaced 120 degrees apart) to transmit and receive acoustic signals between the tool and the borehole wall. This sensor has its own processor, memory, power supply, dynamic directional sensors, and surface communications port so that it can be run as a stand-alone sensor or in conjunction with other MWD sensors. Digital electronics are used to enhance the accuracy of the measurement and extend its operating range.

The AcoustiCaliper tool is available in 6-3/4" and 8" tool sizes. AcoustiCaliper MWD applications include:

- ✓ Environmental correction of MWD gamma ray, resistivity, and neutron data.
- ✓ MWD log quality control.

The AcoustiCaliper tool can operate in any type of mud system:

- ✓ Water-based
- ✓ Oil-based
- ✓ Diesel oil-based
- ✓ Synthetic

The tool range will be slightly reduced in oil-based and synthetic drilling fluids due to increased attenuation of the acoustic signal. The AcoustiCaliper tool has been successfully used in both hard and soft formations. However, in soft formations, the tool range may also be reduced due to the decreased reflectivity of the borehole wall.

## **Resistivity Sensors**

### **EWR-Phase 4**

The EWR-Phase 4 tool has four transmitting antennas, which provide four simultaneous depths of investigation. Since the EWR measurement is taken very quickly after drilling, formation exposure time is greatly reduced. This allows the deep and medium spacings to read true formation resistivity ( $R_t$ ) in most cases. The shallow and extra-shallow spacings were designed to read the transition and flushed zone resistivities, respectively. The EWR-PHASE 4 sensor will work in any type of drilling fluid.

In shales, the amount of formation water trapped inside the pore space and bound to the clay/silt grains controls the response of the sensor. This typically very low resistivity formation water is normally expelled from the pore space upon compaction, resulting in a very gradual increase in shale resistivity with depth. If a shale interval is isolated by impermeable beds, then the formation water cannot escape, resulting in a decrease in shale resistivity throughout the interval. This occurrence usually indicates an abnormal increase in pore pressure, which, if not monitored, can possibly lead to taking a kick.

Since hydrocarbons are insulators, the sensor will respond in hydrocarbon bearing sandstone by showing an increase in resistivity (from the shale baseline) when in oil and gas zones. The magnitude of the increase is controlled by the hydrocarbon saturation of the interval. The resistivity sensor cannot, however, differentiate between oil and gas layers.

Most salt water bearing sandstones will contain very low resistivity formation water, the exception being fresh water aquifers. The free ions in the salt water make the water conductive, resulting in a decrease in resistivity (from the shale baseline).

Crystalline salt has virtually no free ions associated with it, making it a very good insulator. Sensor response in salt shows extremely high resistivity (almost infinite).

The EWR Phase 4 sensor has a vertical bed resolution of 6 inches, and fully developed in 18 inches. The EWR-Phase 4 sensor is used to:

- ✓ Evaluate formation pore pressure
- ✓ Identify thickness of bed boundaries
- ✓ Identify hydrocarbons
- ✓ Identify movable fluids

In shales, the amount of water trapped inside the pore space and bound to clay/silt grains controls the response of the sensor. This typically very low formation resistivity water is normally expelled from pore space upon compaction, resulting in a very gradual increase in shale resistivity throughout the interval.

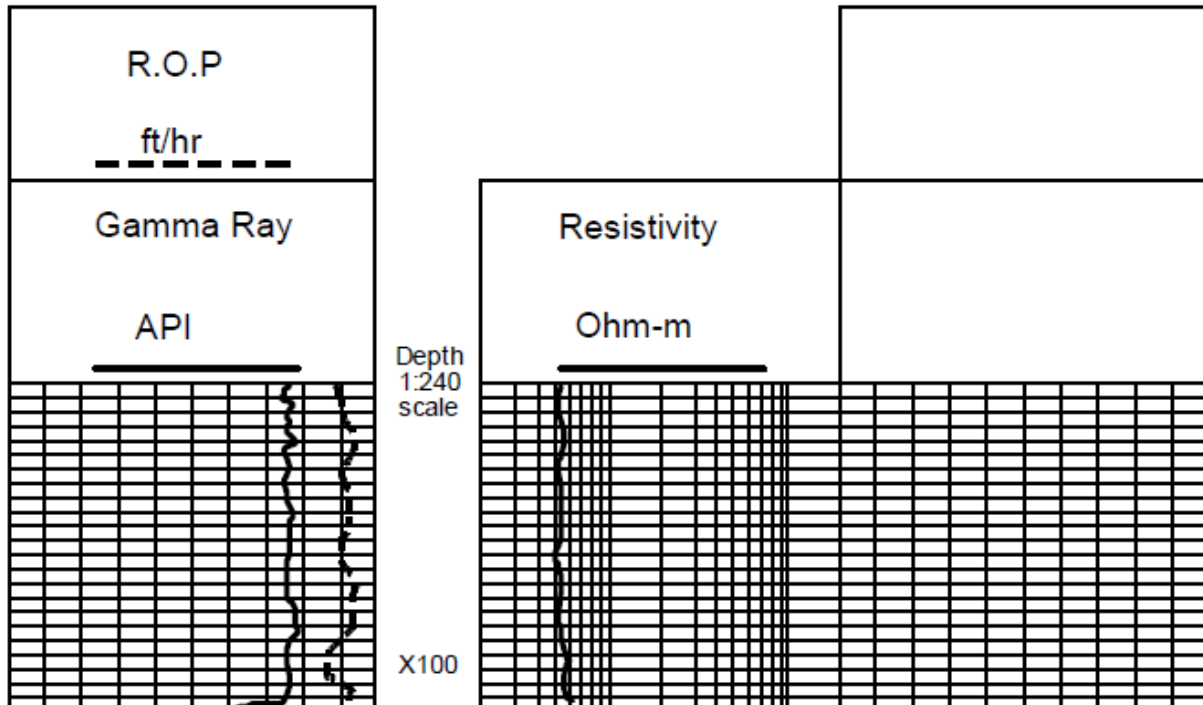

EWR-Phase 4 Response in Shale

If a shale interval is isolated by impermeable beds, then the formation water cannot escape, resulting in a decrease in shale resistivity throughout the interval. This occurrence usually indicates an abnormal increase in pore pressure, which, if not monitored, can possibly lead to taking a kick.

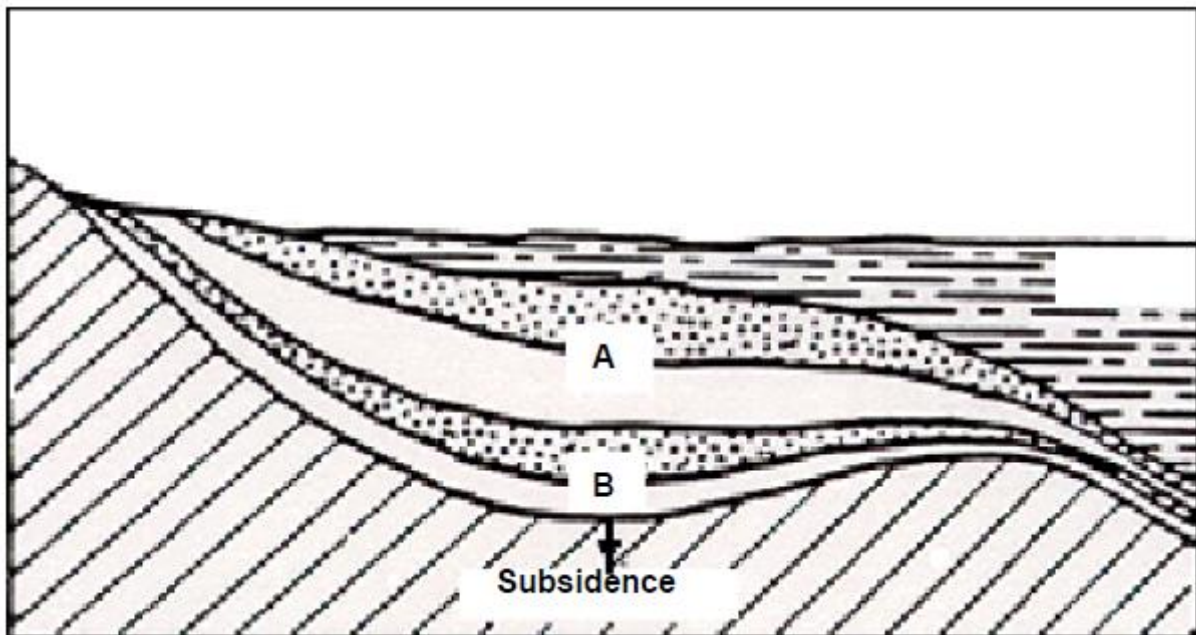

Effect of subsidence

Since hydrocarbons are insulators, the sensor will respond in hydrocarbon bearing sandstone by showing an increase (from the shale baseline) when in oil and gas zones. The magnitude of the increase is controlled by the hydrocarbon saturation of the interval. The resistivity sensor cannot, however, differentiate between oil and gas layers.

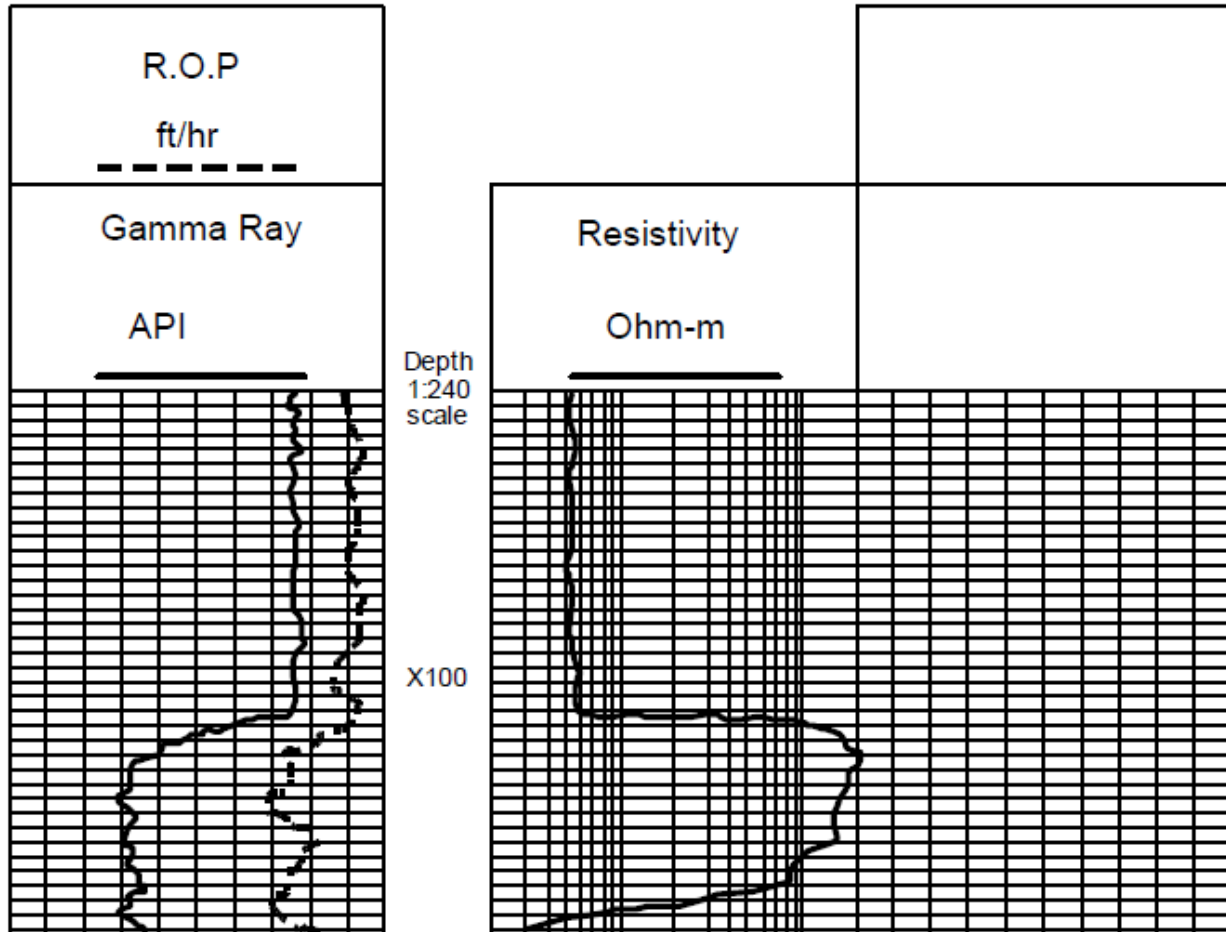

EWR Phase 4 Response in Sand

Most salt water bearing sandstones will contain very low formation resistivity water, the exception being fresh water aquifers. The free ions in salt water make the water conductive, resulting in a decrease in resistivity from the shale baseline. Crystalline salt has virtually no free ions associated with it, making it a very good insulator. Sensor response in salt shows extremely high resistivity (almost infinite).

The EWR-Phase 4 sensor works in all fluid types. (water, oil, gas and air). Curves should develop a normal base line in shale of approximately 1 ohm - m. When in a sand it should move to the left or to low resistivity if the fluid in the sand is oil or gas then it will move to the right or to higher resistivity.



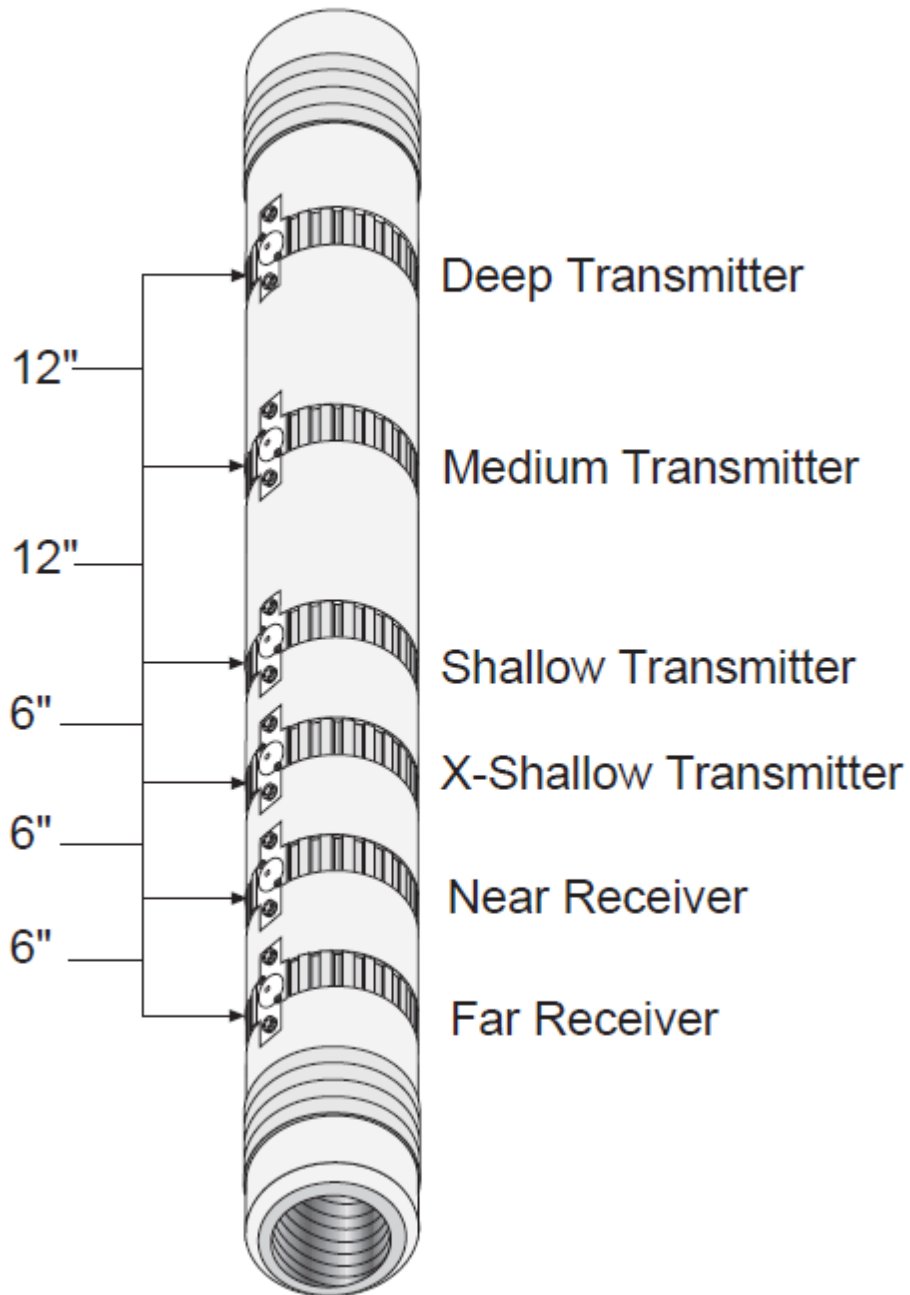

EWR-PHASE 4 tool

The four transmitters include:

- ✓ Extra Shallow (6"/12")
- ✓ Shallow (12"/18")
- ✓ Medium (24"/30")
- ✓ Deep (36"/42")

The two receivers include:

- ✓ Near
- ✓ Far

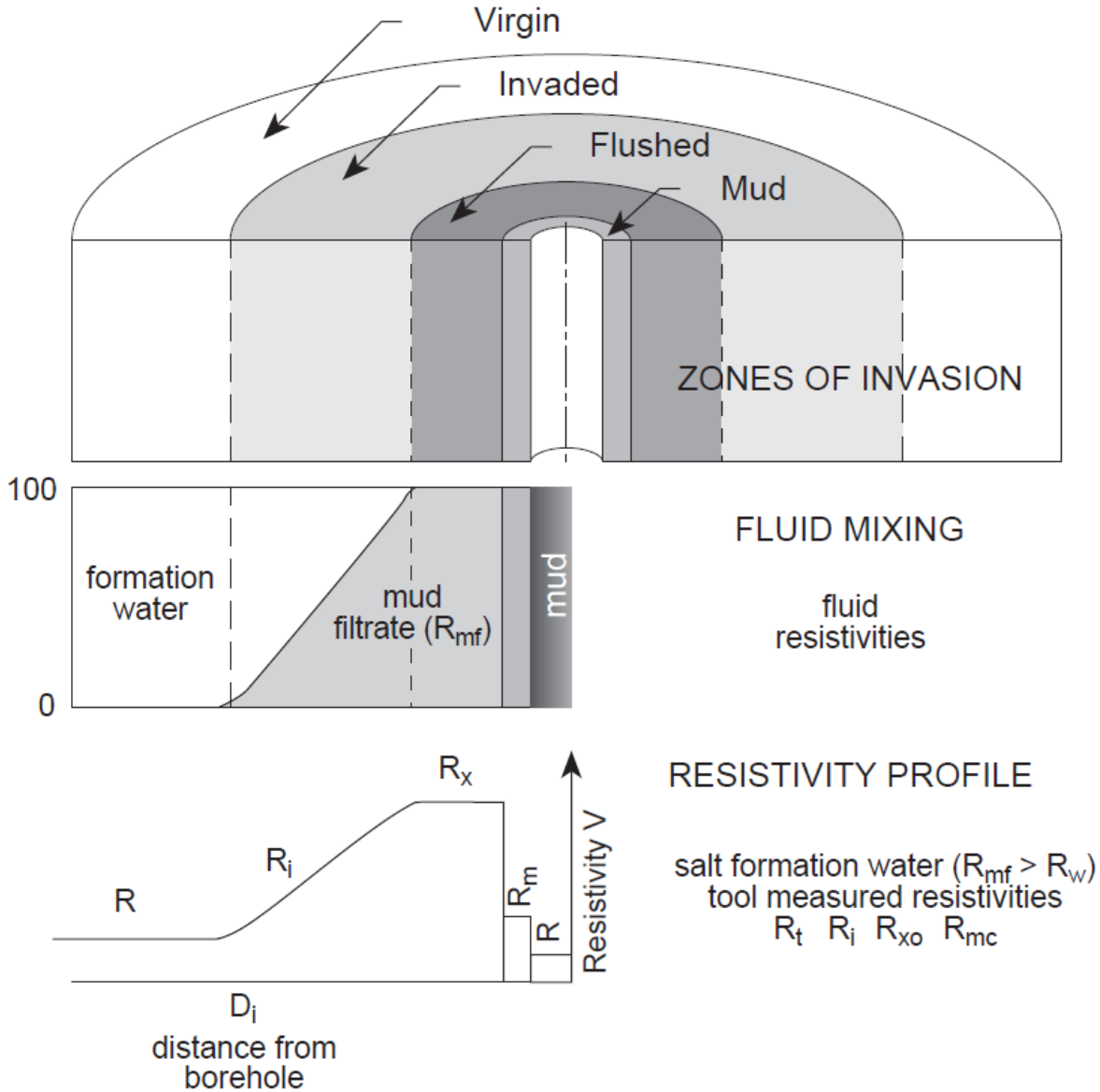

Radial borehole profile

The EWR Phase 4 sensor is available in 6-3/4" and 8" tool sizes. The EWR Phase 4 tool is generally run with gamma and resistivity sensors. The recommended minimum sample period is drilling rate dependent; it is fast enough to obtain appropriate data density. The measurement

range for phase is 0.05 - 2000 ohm-m and for attenuation is 0.1 - 100 ohm-m. System accuracy is +/- 1% (10 ohm-m).

## Porosity Sensors

Porosity sensors include:

- ✓ Neutron (CNP)
- ✓ Neutron (CTN)
- ✓ Density (SLD and SLD A)
- ✓ Sonic (BAT)

## Compensated Neutron Porosity (CNP)

The Compensated Neutron Porosity (CNP) tool measures the hydrogen in the formation.

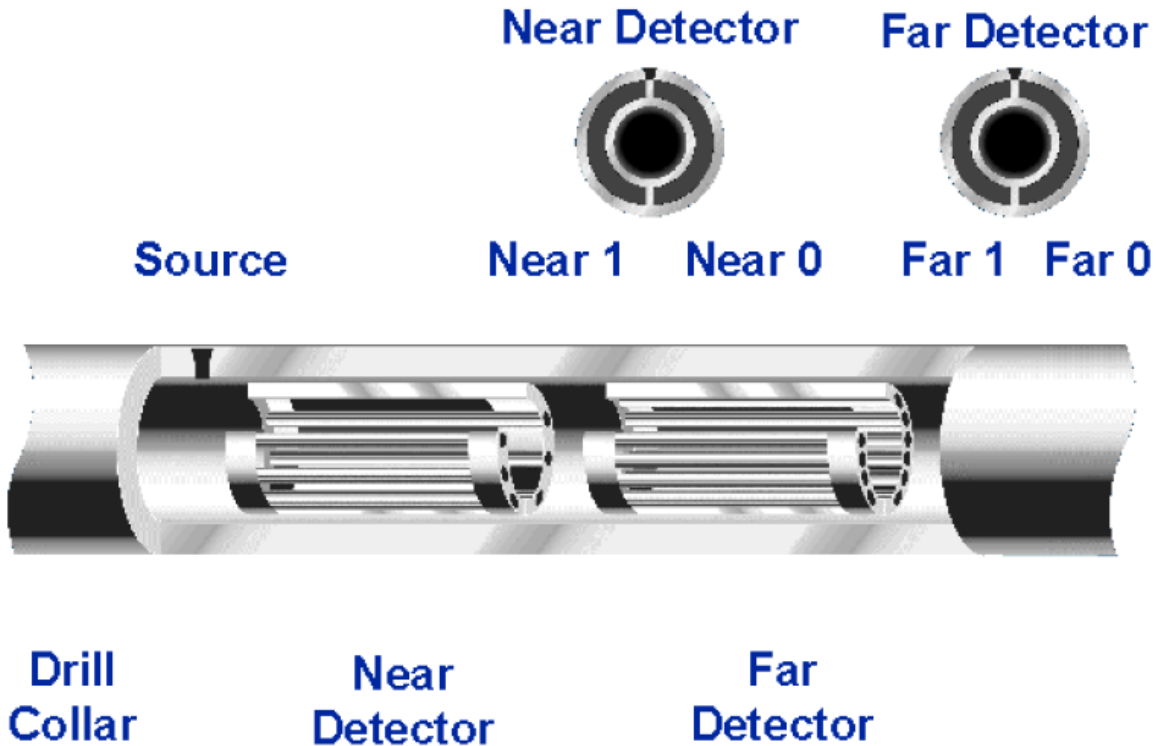

CNP Sensor

The neutrons used in logging come from a source carried in the logging tool (Am<sup>241</sup>Be). These sources contain types of radioactive material which naturally emit fast neutrons that have elastic reactions while they are in the higher energy ranges. However, with each reaction the neutron loses some of its energy. As a result, the neutron may pass through all of the stages - epithermal neutron, slow neutron, and finally thermal neutron - before it finally loses enough energy to be captured by an atom. The CNP sensor employs two redundant banks of Geiger-Mueller tubes at both the near and far detector spacings. These tubes detect neutron-capture gamma rays.

When the neutron is absorbed into or captured by an atom, the atom becomes highly excited (energized) and releases this energy by emitting a gamma ray. This kind of ray is called a gamma ray capture. This is what the CNP detectors measure.

The neutron sensor measures the hydrogen content in a formation. Since a neutron and a hydrogen atom have the same mass, the neutron will transfer most of its energy to the hydrogen when they collide. Hydrogen is the most efficient moderator of neutrons.

Usually, the only fluids that are present in the pore space are gas, oil, or water, which are all composed of hydrogen. Therefore, the more pore space (porosity), the more hydrogen (gas, oil, water) is present and the fewer counts are received at the detectors.

<b>Parameter</b>	<b>Specification</b>
Detector type	Dual banks of Geiger-Muller tubes
Recommended minimum sample period	10 seconds
Measurement range	0 - 70 Porosity Units (pu)
System accuracy	+/- 0.5 to 1 pu @ 20 pu
Statistical Precision	+/- 2 pu @ 20 pu
Vertical resolution	24 inches

#### CNP Sensor Specifications

The CNP sensor is used in measuring porosity and in hydrocarbon typing. The sensor response in shale is controlled by the hydrogen content of the formation pore space. Since shales typically contain a large amount of water, which is high in hydrogen content, the neutron porosity curve will read high values in normally compacted shales. Of course, if an abnormally compacted shale is encountered, the neutron porosity values will be even higher.

Since the hydrogen density of a gas is extremely low, the neutron porosity curve will read abnormally low in a gas bearing sandstone. The large disparity between shale and gas zone neutron porosity values is key in determining when the sensor has crossed a shale/sand boundary. In a gas zone, the neutron will shift right, crossing over the density curve that is shifting left.

Since the hydrogen density of oil and salt water are approximately the same, the neutron porosity curve will read the same value in both of these zones. The sensor is calibrated to read true formation porosity in a clean matrix zone of liquid filled porosity, so the actual value seen on the curve will depend upon the porosity of the interval. The neutron sensor cannot distinguish oil zones from salt water zones.

Water is not associated with crystalline salt, resulting in very low neutron porosity values in a salt zone. Therefore, the more pore space, which is assumed to be filled with gas, oil, or water, the fewer counts will be received at the detectors. With the CNP tool, low counts indicates high porosity as indicated by the presence of the hydrocarbon-bearing fluids filling the pore spaces.

Water is not associated with crystalline salt, resulting in very low neutron porosity values in a salt zone. Therefore, the more pore space, which is assumed to be filled with gas, oil, or water, the fewer counts will be received at the detectors. With the CNP tool, low counts indicates

high porosity as indicated by the presence of the hydrocarbon-bearing fluids filling the pore spaces.

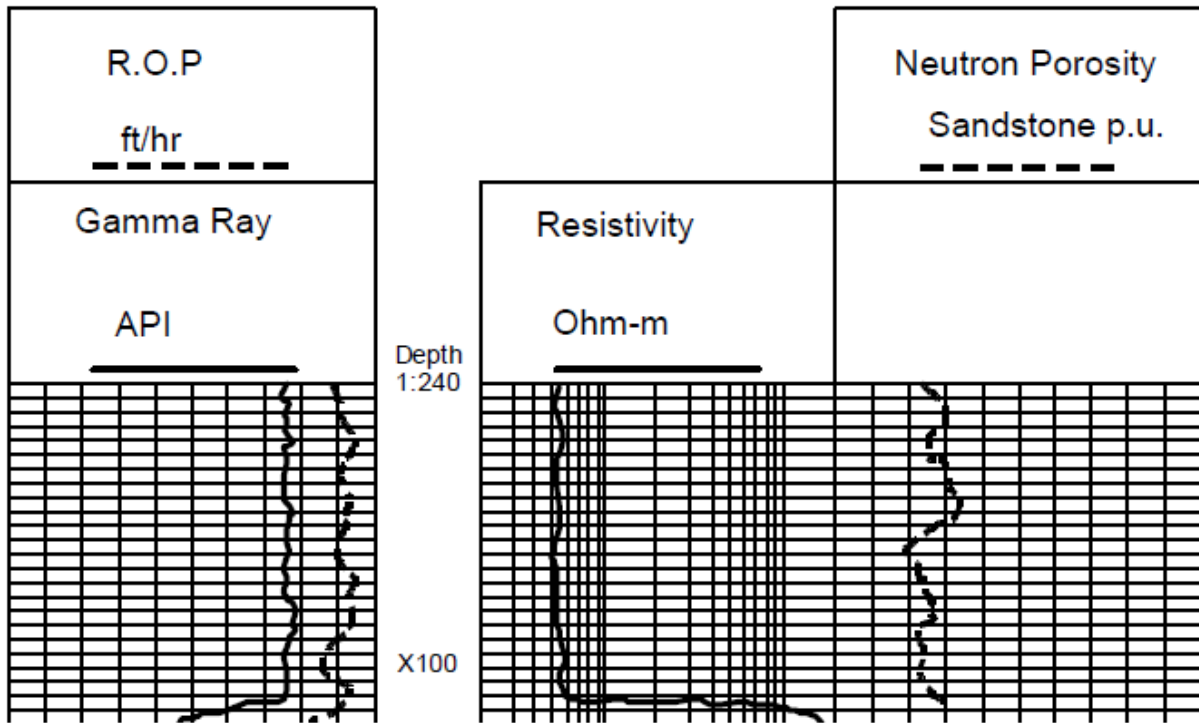

Neutron Porosity Response in Shale

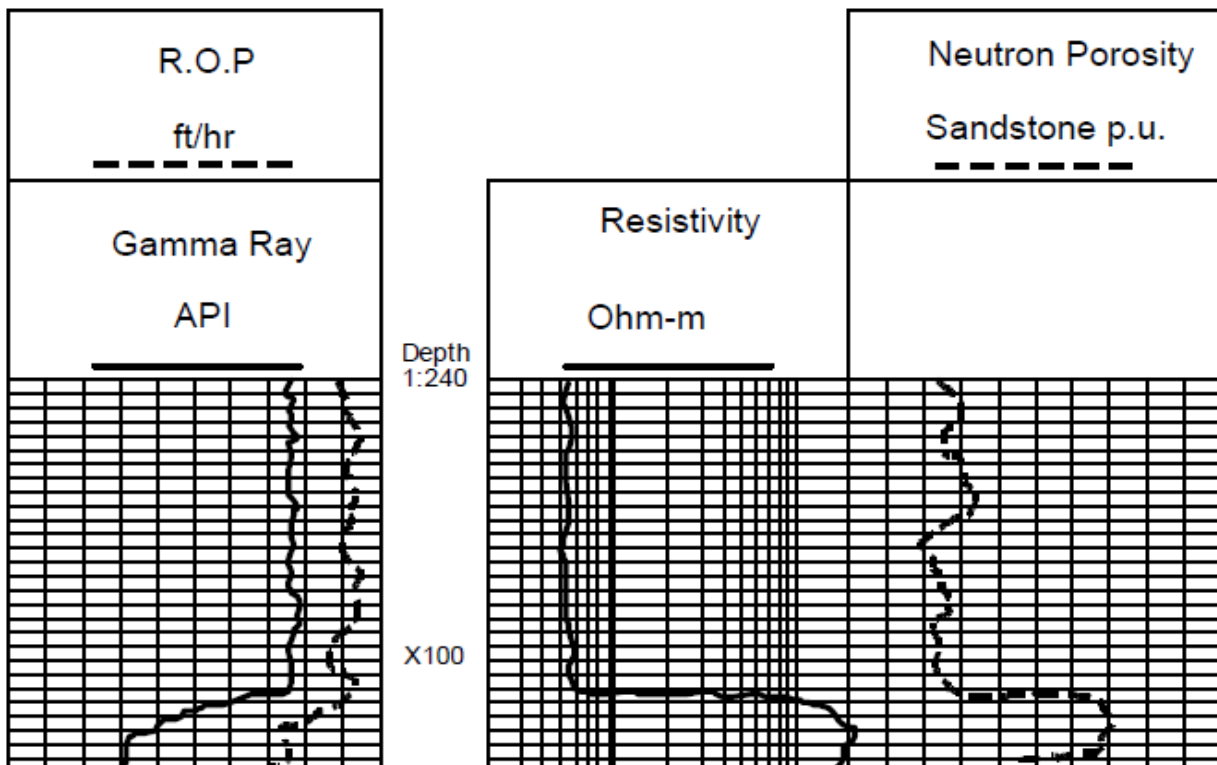

Neutron Porosity Response in Gas Bearing Sandstone

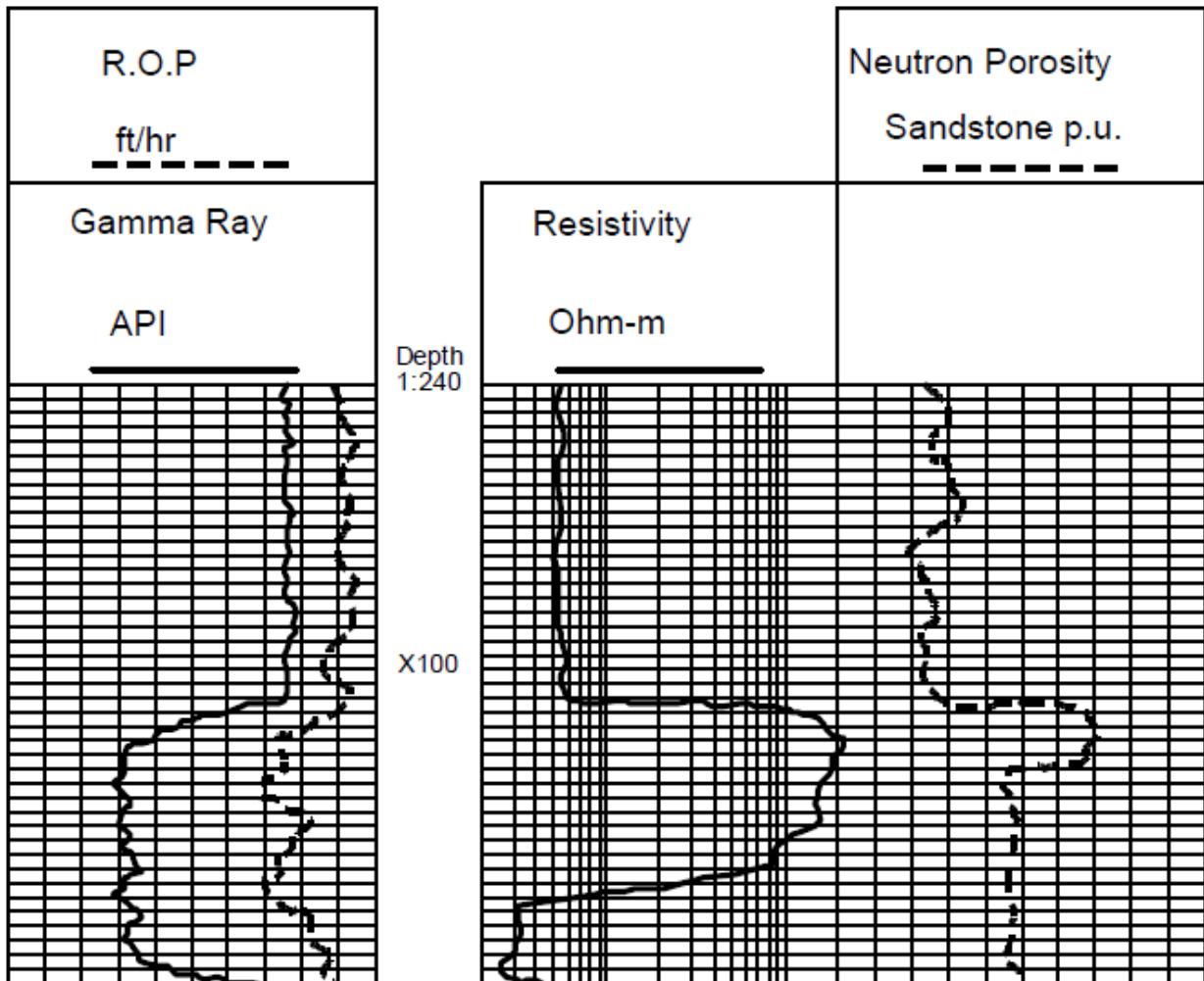

Neutron Porosity Response in Oil or Salt Water

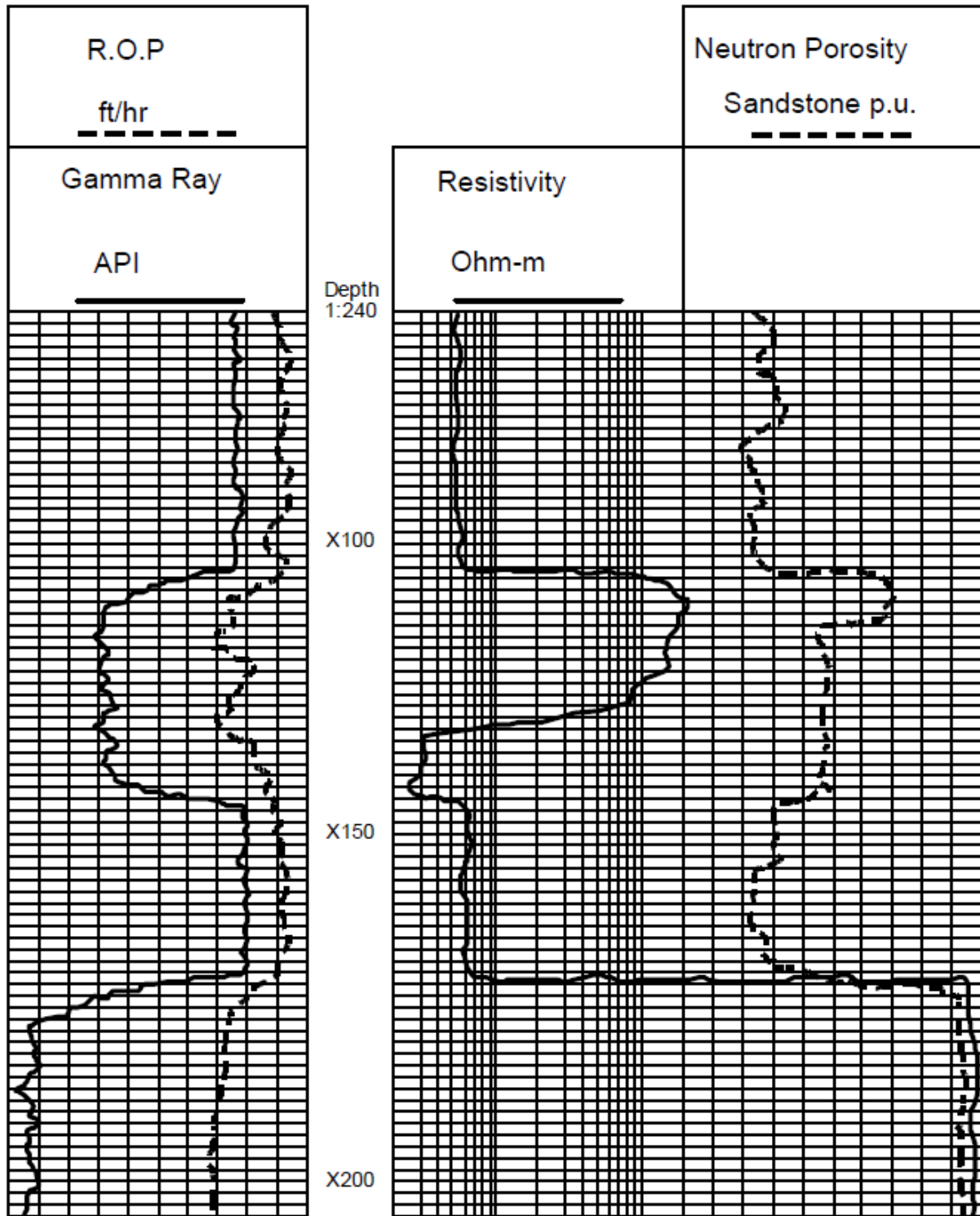

Neutron Porosity Response in Salt

## Compensated Thermal Neutron (CTN)

The Compensated Thermal Neutron (CTN) tool is a sensor that uses a neutron-emitting source with two banks of detectors for determining formation porosity and hydrocarbon typing. The CTN can be used as a stand-alone device, or with other downhole sensors to provide the customer with a full logging suite for formation evaluation. The CTN data is available real-time using the Positive Pulse Telemetry system. The data is also stored in the CTN memory for retrieval once the tool reaches the surface.

The CTN uses two detector banks spaced at different lengths from the neutron source. Each detector is a proportional counter filled with Helium-3 gas. The source emits neutrons at a high energy level, also known as “fast neutrons.” Through the process of collision, the neutrons collide with the formation until they slow down to the thermal state. The CTN counts the number of neutrons it receives at this thermal state. This information can then be used for calculating formation porosity and hydrocarbon typing.

The CTN sensor is a slim hole 4-3/4” neutron porosity tool designed for logging boreholes ranging from 5-7/8” to 6-1/2” in diameter. The CTN sensor can be combined with the slimhole EWR-Phase 4, DGR, SLD, and PWD sensors to provide triple combo logging services in slim holes.

Parameter	Specification
Detector type	Redundant banks of He3 neutron detectors at both near and far spacing
Measurement range	.5 - 100 Porosity Units (pu)
System accuracy	+/- 0.5 @ 0-10 pu and +/- 5 @ 10-50 pu
Statistical Precision	+/-1. 2 pu @ 30 pu
Vertical resolution	24 inches

### CTN Sensor Specifications

The CTN sensor is used for porosity measurements, hydrocarbon typing, and cased hole logging. The sensor response in shale is controlled by the hydrogen content of the formation pore space. Since shales typically contain a large amount of water, which is high in hydrogen, the neutron porosity curve will read high values in normally compacted shales. If an abnormally compacted shale is encountered, the neutron porosity values will be even higher.

## Density (SLD)

The SLD sensor measures the bulk density of the formation using Compton Scattering of gamma rays. The density tool bombards the formation adjacent to the wellbore with gamma rays from a 2.0 Curie Cesium source. It also uses two scintillation detectors (one near spaced and one far spaced) located in a pressure housing. Various SLD designs are available for use in the following hole sizes:

- 6-1/2”
- 8-1/2”
- 9-7/8”



• 12-1/4"

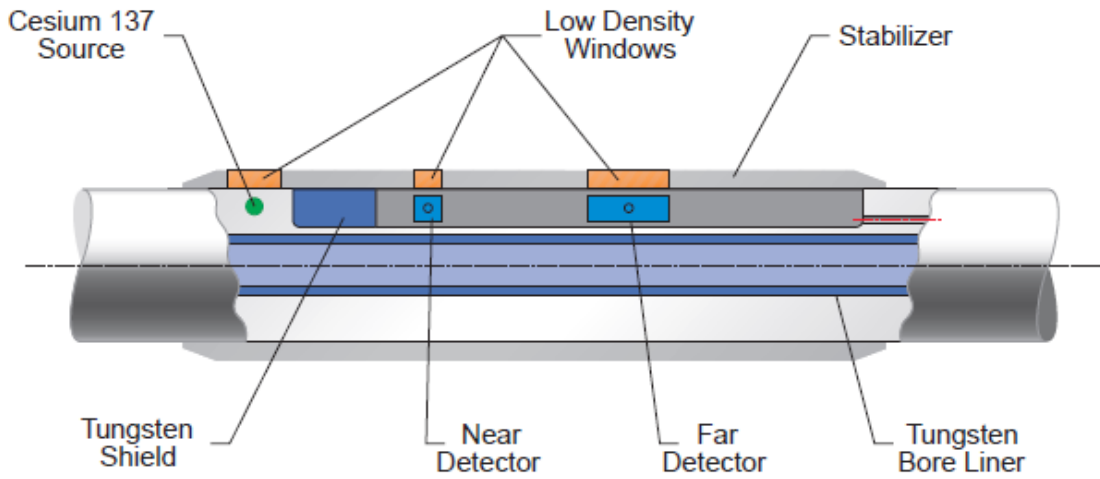

SLD tool

Dual spacing corrects for the presence of mudcake and standoff from the borehole wall. Gamma rays (662-keV) are emitted from the source and interact with the formation. Compton scattering occurs. Compton scattering is a phenomenon in which a gamma ray collides with an electron and loses some of its energy. This is key because this allows us to measure electron density, which is directly proportional to bulk formation density.

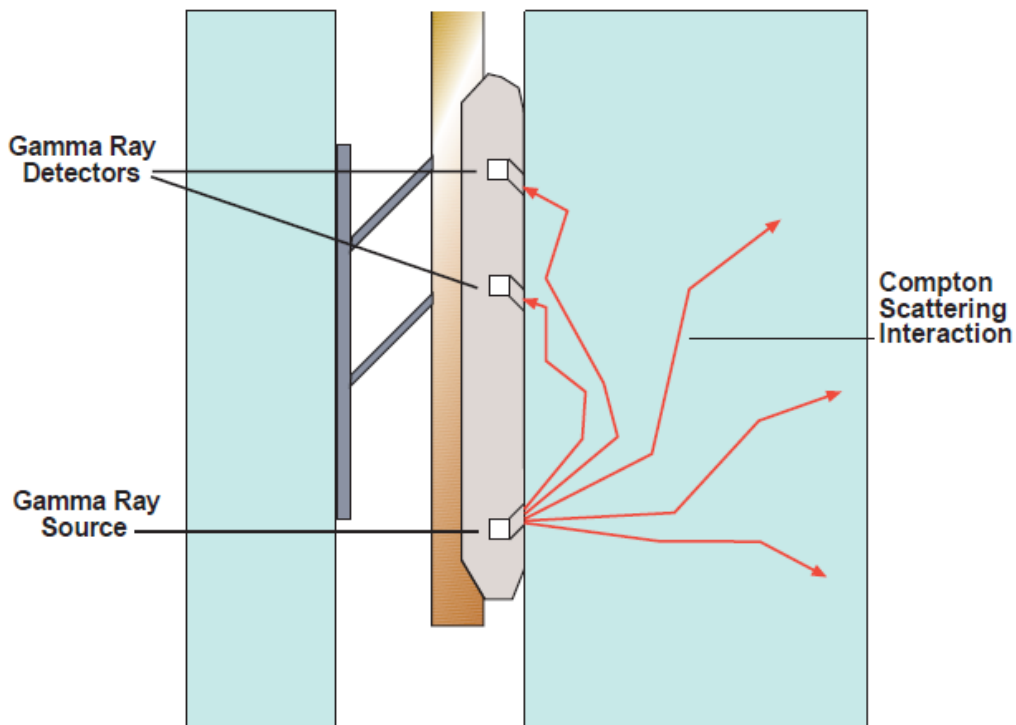

Compton scattering interaction

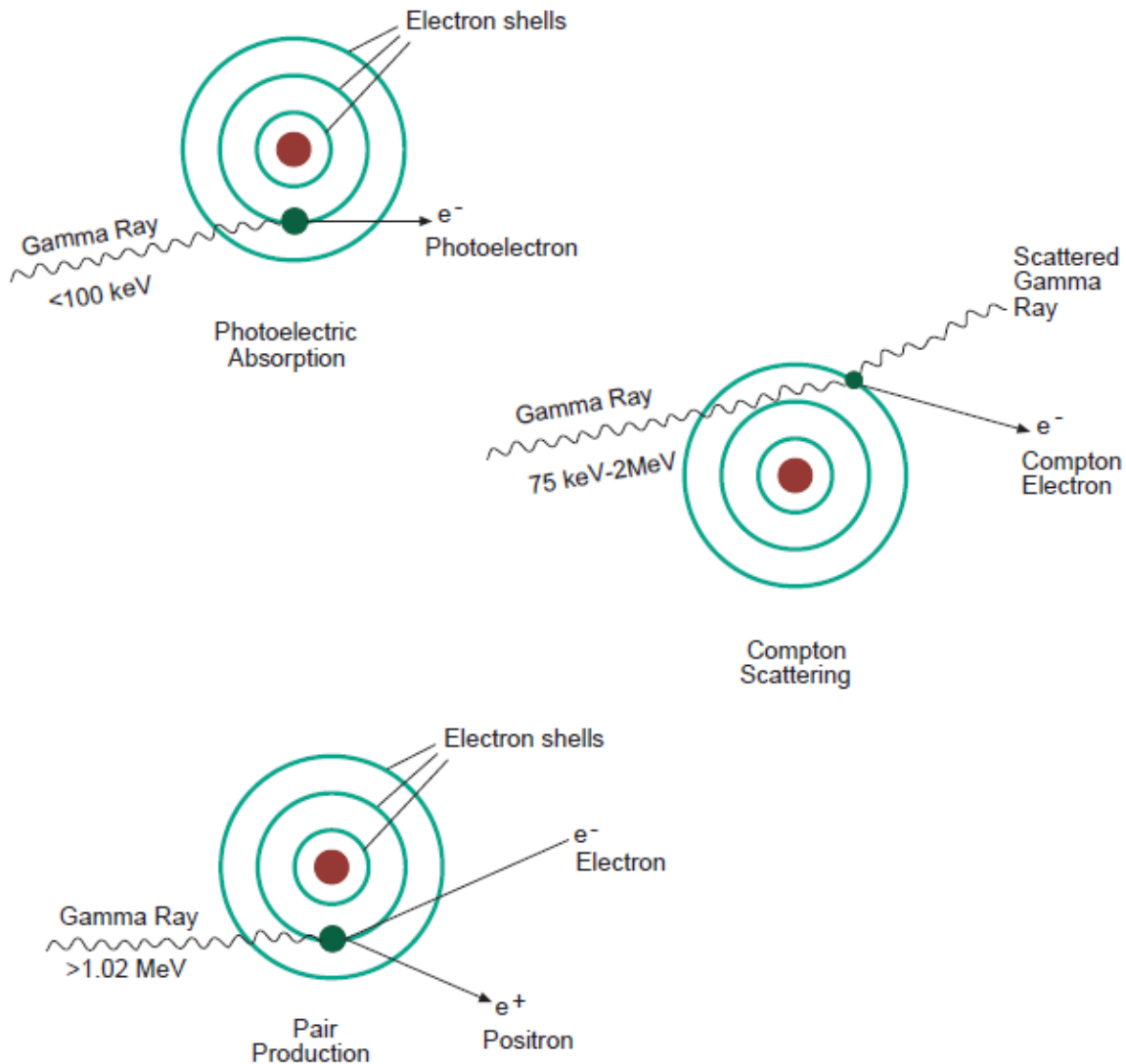

### Gamma ray interactions

The returning gamma rays are counted by detectors mounted on a skid pressed against the borehole wall. By pressing the detectors against the borehole, the effects of the mud and the mudcake can be eliminated. If a formation has a high porosity, which would mean low bulk formation density, then high counts will be seen at the detectors. If the formation has a low porosity (high bulk formation density), then low counts will be seen at the detectors.

It is important to remember that we cannot directly measure bulk formation density, but rather we must measure bulk electron density and infer bulk density from it.

Bulk density can be related to porosity when the lithology is known. The equation relating density to porosity is similar to the Wyllie's (sonic) equation:

$$\text{Density Porosity} = (p_{ma} - p_b) / (p_{ma} - p_f)$$

- $p_b$  = the formation bulk density from the log
- $p_{ma}$  = the matrix density at zero porosity
- $p_f$  = the density of the formation fluid (1 g/cc)

Different types of matrix material have different bulk densities, as shown in the chart below. All bulk densities assume zero porosity.

<b>Matrix</b>	<b>Bulk Density (g/cc)</b>
Sandstone	2.65
Limestone	2.71
Dolomite	2.87
Anhydrite	2.98
Salt	2.03
Shale	2.30 -2.70

Bulk densities of various matrices as used in the density porosity formula

Gas zones have a much lighter total matrix than a water or oil zone, thus you get a high density porosity. Shales respond with a low density porosity.

The stabilizer blades in the SLD tool are mounted in the collar in order to maintain wall contact during drilling. Low density windows through one of the blades allows the returning gamma rays to be seen by the detectors more readily.

The sensor response to shale is controlled by the electron density of the formation. Since formation density normally increases with depth, i.e., compaction, we can conclude that density porosity values in shales should decrease with depth. From our previous discussion of abnormally compacted shales, we should see an increase in density porosity values in these intervals. Used in conjunction with the neutron porosity curve, we can identify shale intervals by noticing the 4 - 6 division separation between the curves, with the neutron porosity curve tracking to the left of the density porosity curve.

Since gas has an extremely low electron density, the density porosity curve in gas bearing sandstones should show an increase (from the shale values) through these intervals. This should cause the curve to shift to the left and cross over the neutron, which will shift to the right.

Since the electron density of oil and salt water are approximately the same, the density porosity curve should read the same values in oil and salt water bearing sandstones. The curve should fall somewhere between the shale and gas zone responses of the sensor. As with the neutron sensor, the density sensor is calibrated to read true formation porosity in a clean matrix zone of liquid filled porosity, so the actual value seen on the log will depend upon the porosity of the interval. If the neutron and density porosity curves are plotted using compatible scales, then they should overlay each other in oil and water zones, assuming it is processed with the correct matrix. The density sensor cannot distinguish oil zones from salt water zones.

Crystalline salt has a bulk density of approximately 2.05 g/cc, so the density porosity values should track along the porosity that corresponds to this bulk density. The density porosity value will depend upon the matrix used for processing.

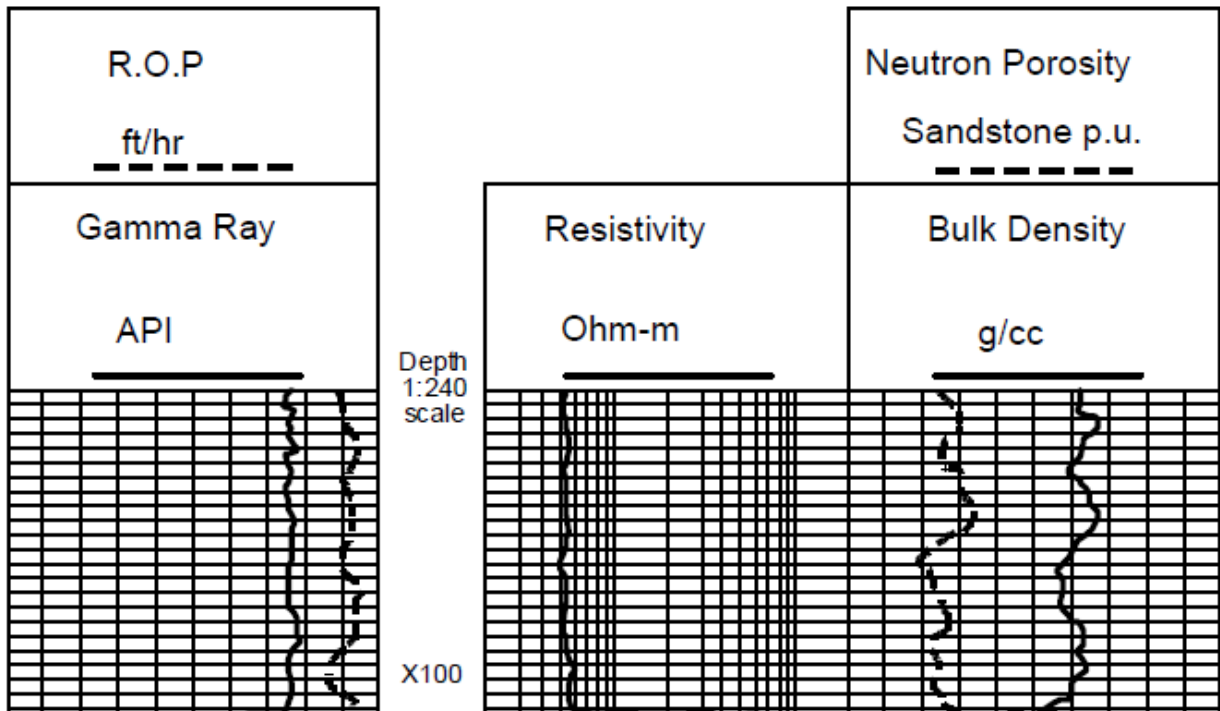

Bulk Density Response in Shale

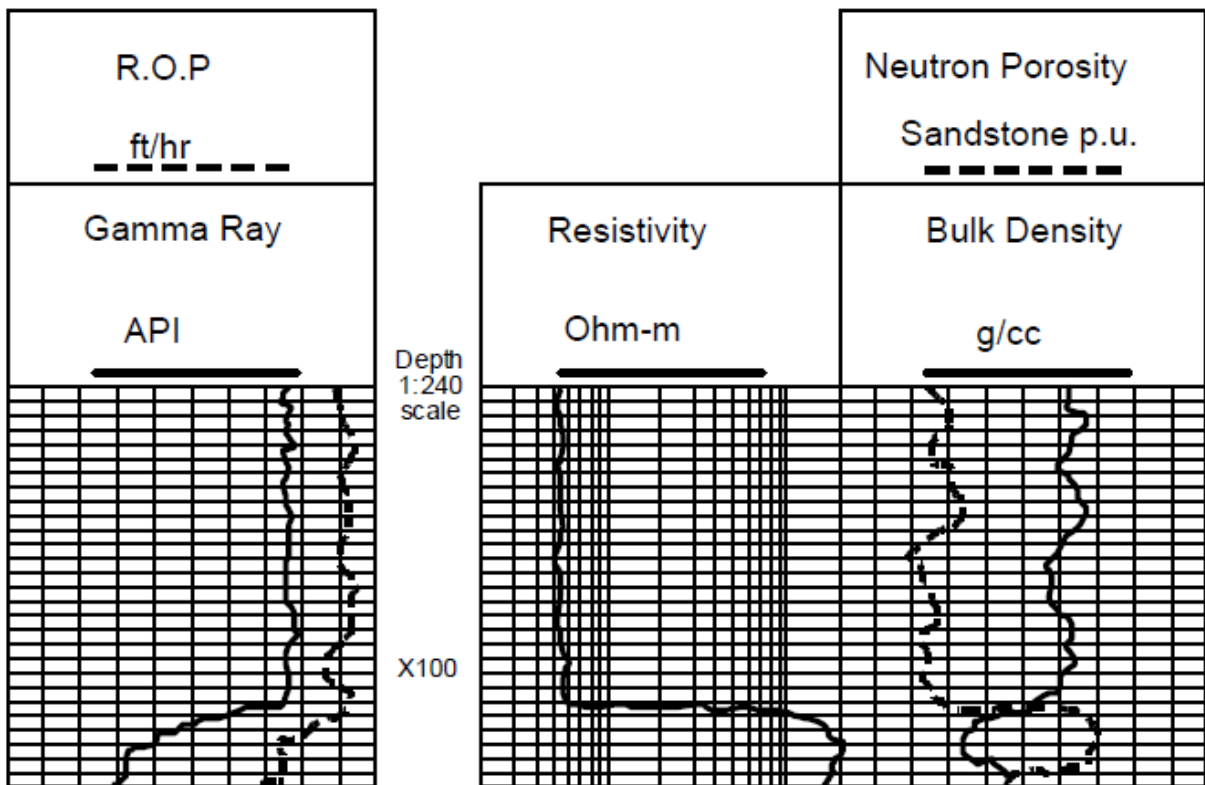

Bulk Density Response in Gas Bearing Sand

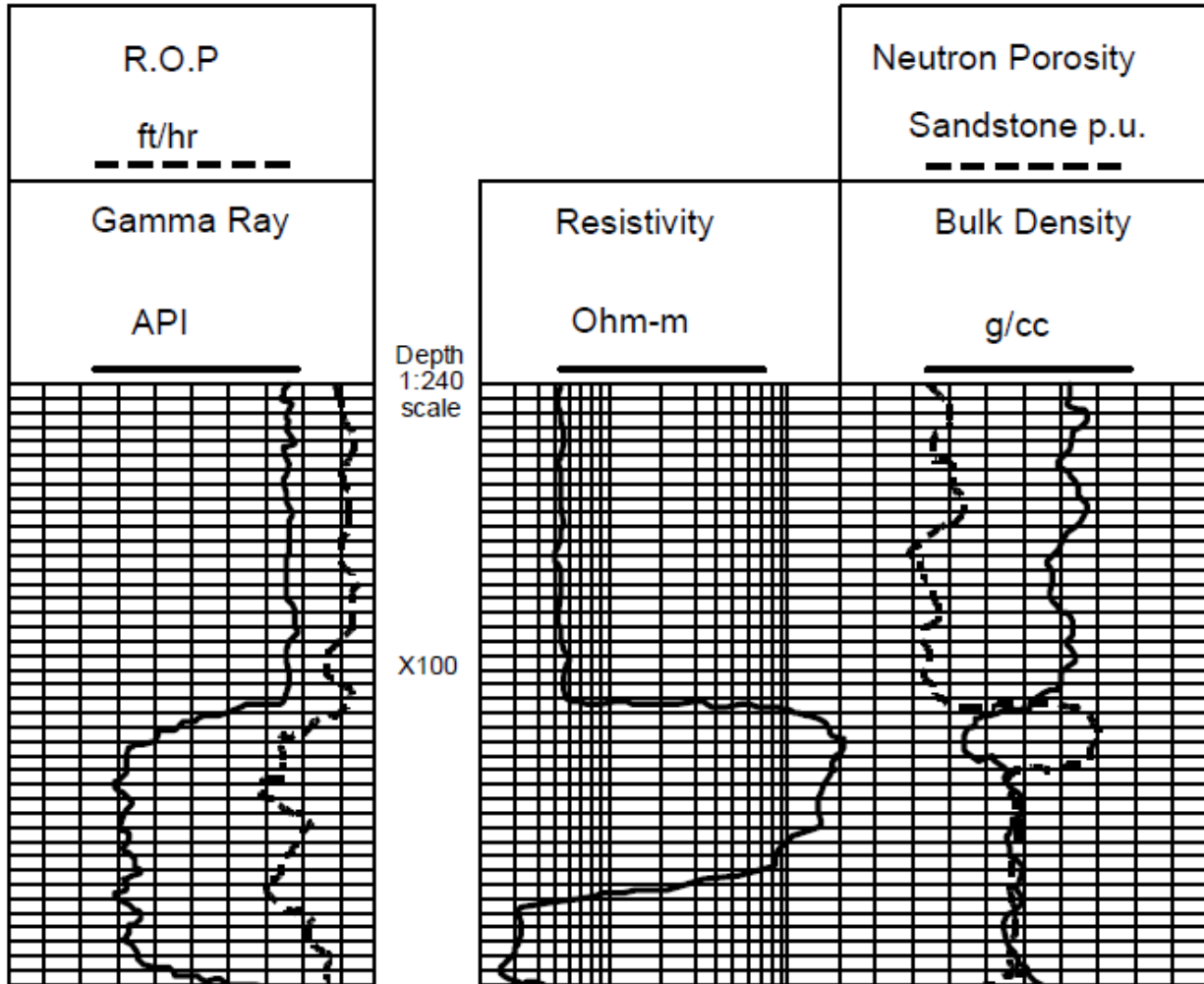

Bulk Density Response in Oil and Salt Water

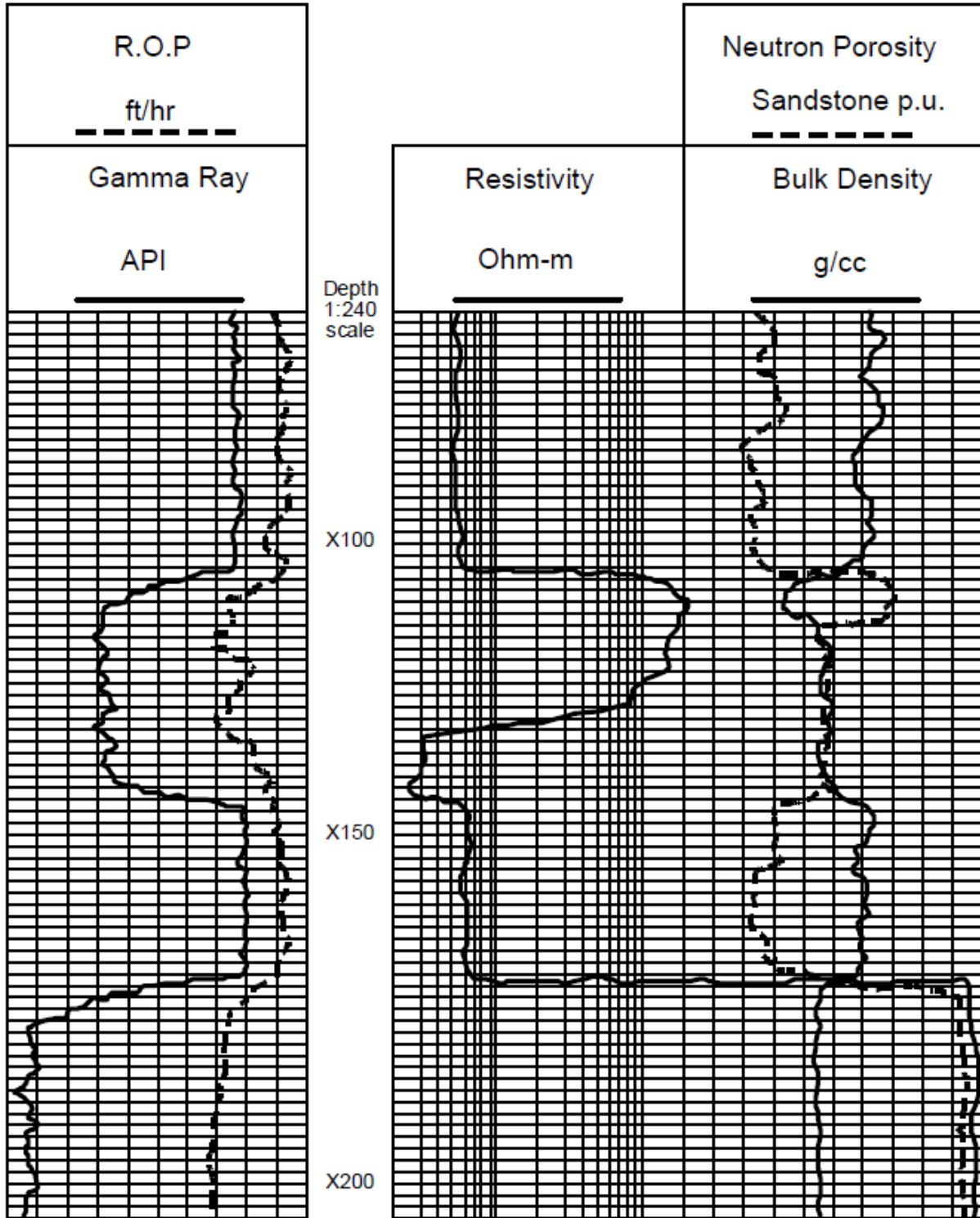

Bulk Density Response in Salt

The SLD sensor is used in conjunction with the neutron porosity tool. This allows us to identify shale intervals by noticing the 4-6 division separation, with the neutron porosity curve tracking to the left of the density porosity curve. Since gas has an extremely low electron density,

the density porosity curve in gas bearing sandstones should show an increase from the shale values through these intervals. This should cause the curve to shift to the left and cross over the neutron curve, which will shift to the right.

## Sonic (BAT)

The Bi-modal AcousTic tool (BAT) is a dual array monopole/dipole MWD sonic tool.

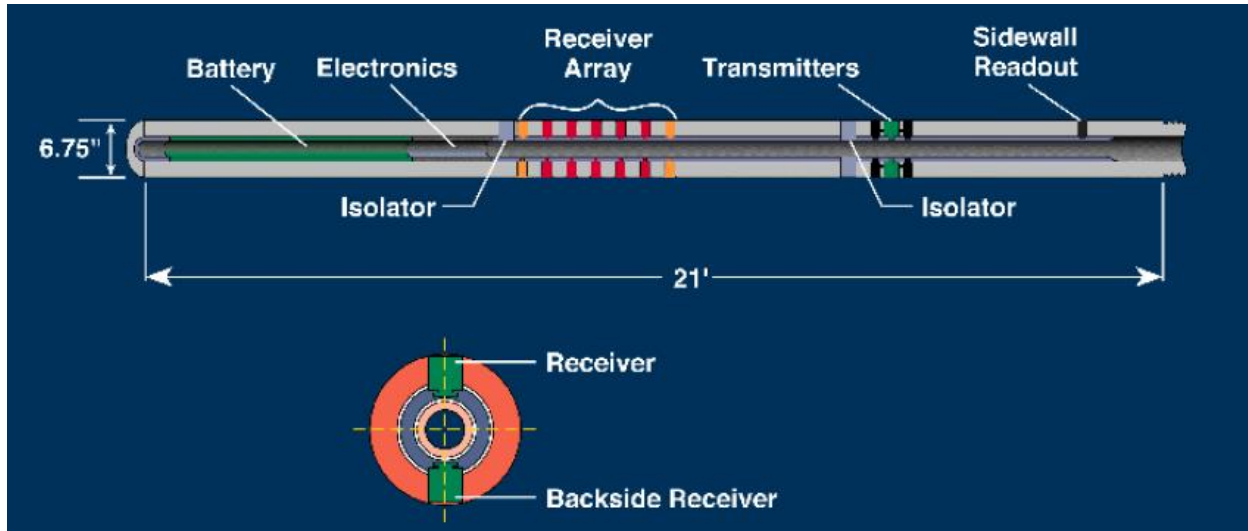

The BAT tool contains two seven-receiver arrays (front and back) and two high power, dual frequency transmitters. The BAT tool also contains full waveform memory storage (256 MB/512 MB) and two powerful digital signal processors for fast download delta -t calculations. The BAT tool is available in 6-3/4" and 8" sizes with a 4-3/4" size in prototype testing. The tool is 21 feet long with 2 opposed transmitters (front and back) and 14 receivers (7 front and 7 back). The transmitter to first receiver spacing is 4.5 feet; the receiver to receiver spacing is 6 inches.

BAT applications include:

- ✓ Porosity
- ✓ Real-time seismic time/depth correlation
- ✓ Real-time pore pressure determination
- ✓ Gas detection ( $V_p/V_s$ )
- ✓ Wireline replacement (with other LWD sensors)
- ✓ Rock mechanical properties for wellbore stability, bit wear, stimulation, and completion
- ✓ Seismic interpretation applications (AVO, velocity modeling, etc.)

Compressional only applications include porosity, seismic time/depth correlation and pore pressure evaluation. Applications with shear include rock properties, gas detection, AVO.

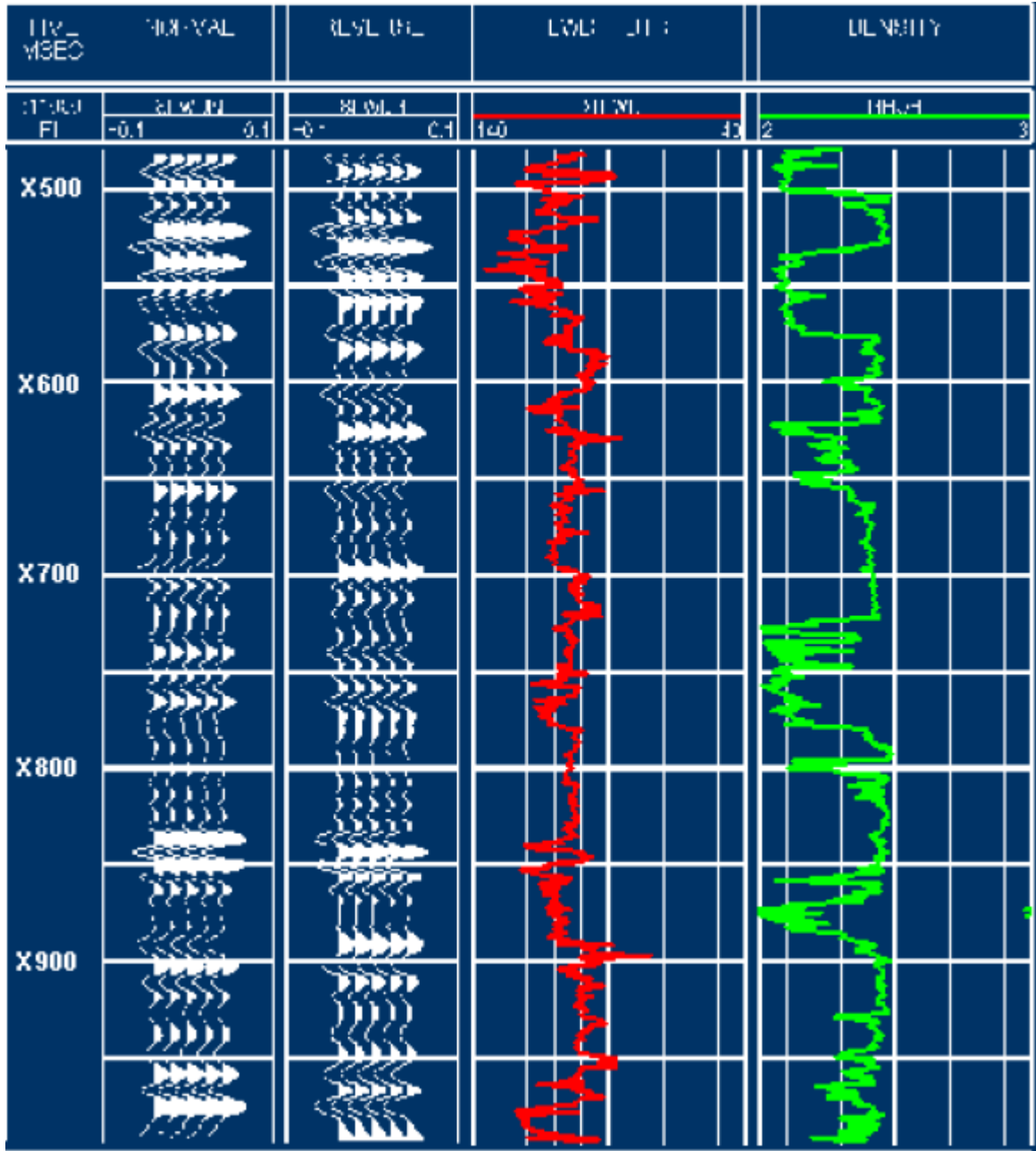

BAT Sensor Response (Synthetic Seismogram vs ΔT)

The sonic log measures the shortest time required for a compressional wave to travel vertically through one foot of formation adjacent to the well bore. The sonic tool takes advantage of the fact that a sound wave travels at different speeds through different materials. These travel times assume a formation with zero percent porosity. The sonic travel time can then be related to porosity if the matrix is known.

The Wyllie equation is used to relate travel time and porosity.

$$\rho = (t - t_{ma}) / (t_f - t_{ma})$$

t = travel time from the log



tma = is the matrix travel time at zero porosity  
 tf = is the fluid travel time (assumed to be 190 μsec/ft)

The table below shows the matrix travel time per foot at zero porosity for different lithologies as used in Wyllie’s equation.

Matrix travel time in various lithologies

Rock	Matrix Travel Time Per Foot @ 0 Porosity
Sandstone	55.5
Limestone	47.5
Dolomite	43.5
Anhydrite	50.0
Salt	67.0
Shale	130.0

**Drilling Efficiency Sensors**

Sperry-Sun’s Drilling Efficiency Equipment Package (D.E.E.P) provides the driller with measurements that help avoid drilling problems and optimize the drilling process. Drilling efficiency sensors include:

- ✓ Pressure While Drilling (PWD)
- ✓ Drilling Dynamics Sensor (DDS)
- ✓ Weight on Bit/Torque on Bit (WOB/TOB)
- ✓ AcoustiCaliper (ACAL)

**Pressure While Drilling (PWD)**

The Pressure While Drilling (PWD)® sensor is a drilling performance tool that provides continuous downhole measurement of internal and annular pressure. These pressure measurements provide information on downhole hydraulics and fluid performance. This sensor is normally used with other formation evaluation and directional services; however, it also operates as a standalone service.

The PWD sensor is an insert-mounted, pressure measuring tool. Dual Quartzdyne transducers continually measure both internal and annular pressure under pumps on or pumps off conditions. The smart sensor electronics perform many functions.

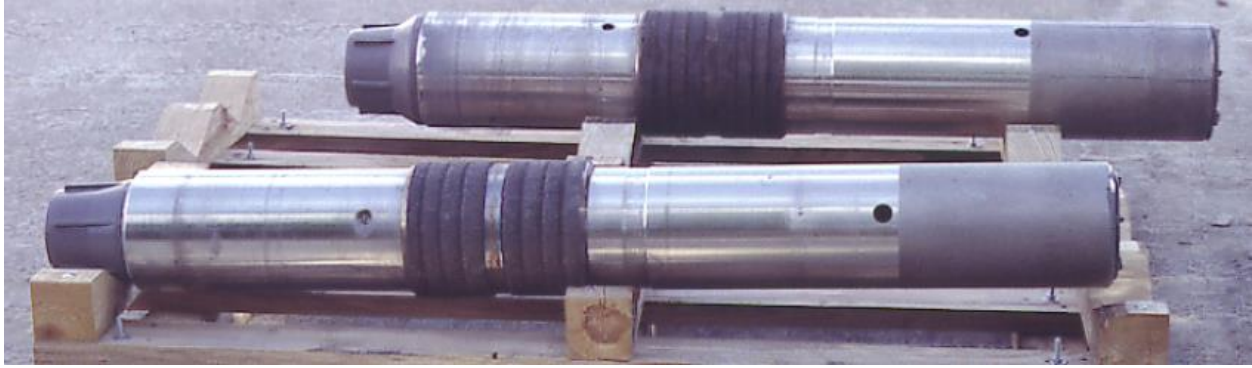

## PWD tool

The PWD insert is composed of:

- ✓ Controller module
- ✓ Counter board
- ✓ 2 Quartzdyne transducers
- ✓ Sidewall readout
- ✓ Two piece insert frame

The counter board is in a sealed can, mounted on the insert frame. This board monitors the frequency of the oscillators in the transducers and converts the frequency changes to values used by the controller module to calculate the pressure. All size tools use the same counter board.

The Quartzdyne transducers contain two crystal oscillators, mounted in a sealed cylindrical container. One of the oscillators is subjected to the pressure being read. The other, a reference not subjected to the pressure, is used to cancel the effect of temperature on the transducer and thus the effect of temperature on the pressure readings. There are two transducers mounted on the sensor. One measures annular pressure and the other measures internal pressure.

The mud isolator consists of a rubber bladder that separates an oil-filled passage to the transducer from the drilling fluid. It is filled with de-aerated oil and sealed with the bladder during tool assembly. If it is overfilled, thermal expansion exerts a pressure on the transducer which shows up as a pressure reading above ambient when tested on the deck. This effect shows up only at the surface where the pressure readings are on the very low end of the calibrated range. When outside pressure exceeds the thermal expansion pressure reading, the sensor responds correctly.

PWD Sensor Response

Parameter	Specification
Accuracy including Hysteresis	+/- 0.05%
Total Error	+/- 12 psi
Hysteresis	+/- 1 psi/bit
Repeatability	+/- 4 psi
Resolution	Recorded: 1 psi/bit Real Time 0.05%

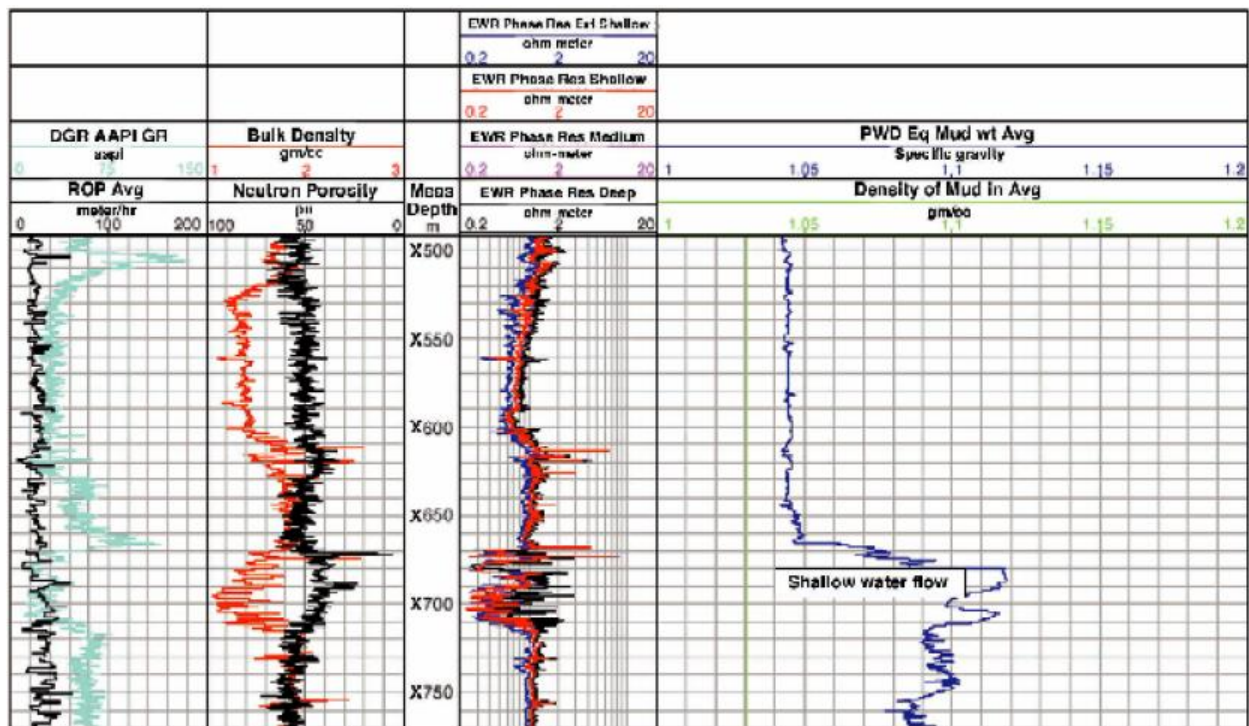

Shallow water flow detection - water and sand influx into salt water mud

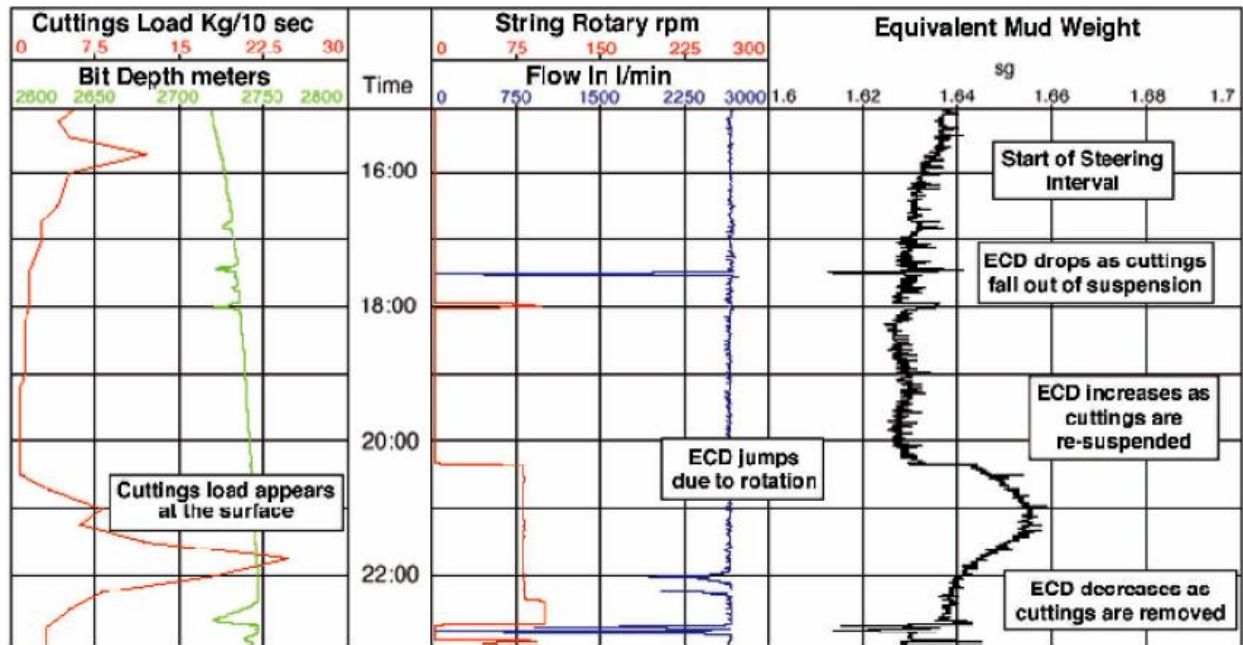

Hole cleaning - Effect of cuttings settling and pipe rotation

PWD applications include:

- ✓ Monitor leak of test (LOT) and lost circulation
- ✓ Detect flow/kick
- ✓ Clean hole and avoid collapse
- ✓ Monitor mud properties
- ✓ Optimize drilling practices
- ✓ Perform underbalanced drilling

### Drilling Dynamics Sensor (DDS)

Destructive downhole vibration has been shown as the probable culprit of many drill bit and drillstring failures. The most effective way to control vibration has proven to be modifying the RPM and WOB operating parameters based on feedback from the real-time downhole vibration measurements. This provides engineers with a method to diagnose the condition using real-time DDS data, and take corrective actions based on the condition.

However, in very hard and abrasive formations, finding a rotary speed that completely eliminates vibrations is sometimes impossible. Thus, this guideline also includes other remedies that can be taken (changing the BHA and the bit, using special hardware, etc.) when operating parameter control proves unsuccessful.

In order to successfully control the vibrations, wellsite engineers should have a basic understanding of drilling dynamics. Following are the most critical factors that affect downhole vibration:

The amount and form of toolstring vibration is influenced by a number of factors:

- ✓ Operating Parameters (RPM/WOB)
- ✓ Hole Angle

- ✓ BHA
- ✓ Drill Bit
- ✓ Lithology
- ✓ Hole Size

### **Operating Parameters (RPM/WOB)**

The main source of excitation in drilling is the rotation of the drillstring and the drill bit. Thus, the primary method to control the downhole vibrations is to find an optimum RPM that will create a “safe” vibration level.

Centrifugal force is proportional to the rotary speed squared. The higher the RPM, the higher the imbalance force to the bit and drillstring, and the higher the energy to create lateral vibrations or BHA/bit whirl. On the other hand, torsional vibration is often associated with a lower rotary speed (higher frictional torque) so running a low RPM is not desirable in the environment that is prone to torsional vibration.

Drillstring “resonance”, when the rotary speed matches one of the natural frequencies of the drillstring, can also create large scale oscillations that should be avoided. Unfortunately, due to the changing boundary conditions and the wellbore contacts, predicting the critical speed to avoid the lateral shocks/whirl is usually not possible.

Sometimes significantly reducing the rotary speed of the drillstring might be helpful. For example, a downhole motor may be used so that the RPM imparted at the surface may be greatly reduced, which in turn minimizes the dynamic energy in the drillstring. This has been shown to be quite successful in some situations.

The secondary method to control vibrations in real-time is to change the WOB. Generally, WOB influences bit vibration more than drillstring vibration. For example, higher WOB generally will increase the stability of a PDC bit but aggravate the roller cone bit vibrations. Higher WOB sometimes can also cause the BHA to buckle, resulting in contact between the collars and borehole wall which in turn cause BHA whirl and lateral shocks, etc.

When a change of RPM or WOB is required, a 10-15% change in value is usually recommended if it is within the constraints of the operator.

### **Hole Angle**

Severe drillstring lateral vibrations are more likely to occur in vertical or near vertical wells which is due to the fact that gravity tends to reduce the amount of lateral displacement in directional and highly deviated wells. This has been shown in the DDS data collected to date as well as in the published literature in the drilling industry. However, torsional vibration (stick slip) is more likely to occur in deviated holes due to the higher frictional torque.

### **BHA**

BHA design is an important factor in drilling dynamics. The use of a downhole drilling motor can reduce the energy of interactions between the rotating BHA and the wellbore, thus eliminate the chance of BHA whirl and lateral shocks. For the conventional assemblies, it has been shown that a packed hole assembly is subjected to less vibrations than the pendulum. The number of collars between stabilizers should be minimized while drilling in very hard formations. This is because long unstabilized spans, such as those found in pendulum assemblies used in vertical drilling, encourage bending and help induce collar and bit whirl.

Because undergauge stabilizers are more likely to develop BHA whirl than full gauge stabilizers, if possible full gauge stabilizers should be used in place of undergauge stabilizers - especially on vertical or near vertical wells. If an MWD tool is to be protected from harmful vibrations, then it should be surrounded by full gauge stabilizers. Bit vibration can also be reduced if it is well stabilized. In extended reach and high angle wells, spiral stabilizers can be used to reduce drag.

Tool joints should be inspected at regular intervals if high levels of vibration have been shown in the DDS data. During inspection, particular attention should be paid to collars above the uppermost stabilizer.

### **Drill Bit**

An anti-whirl PDC bit is more stable than a conventional PDC bit. A PDC bit has the tendency to whirl at high RPMs and in hard formations. A dull or undergauge PDC bit can induce torsional vibration of the drillstring (stick-slip).

Roller cone bits are commonly associated with bit bounce. It also subjected to whirl at very high RPMs in hard formations.

### **Lithology**

Vibrations always increase with formation strength.

### **Hole Size**

Oversize hole can increase the instability of the drill bit and drillstring increasing the likelihood of lateral shocks, BHA whirl, and bit whirl.

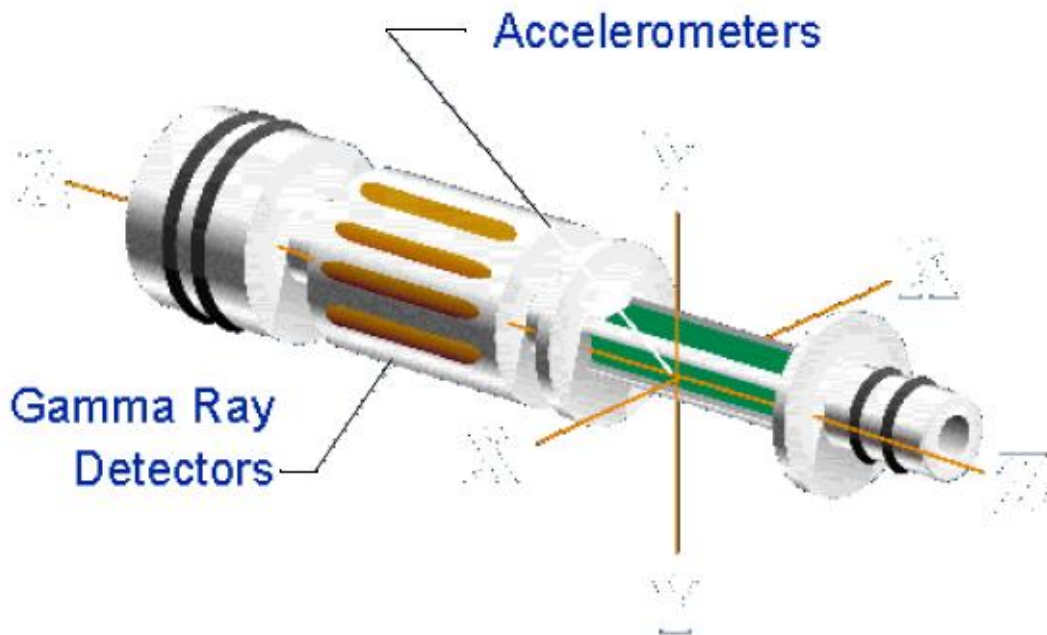

### **DDS Sensor**

The DDS sensor consists of triaxial accelerometers and electronics mounted on the insert of a Dual Gamma Ray (DGR) sensor. It measures lateral, torsional, and longitudinal

accelerations. Average, peak, and instantaneous (burst) accelerations are measured for each of the three axes. This detects vibration severity and mode (i.e., bit bounce, lateral shock, and bit whirl).

DDS Sensor Response

Parameter	Specification
Peak Measurement	0 - 200 G peak
Average Measurement	0 - 40 G average
Low Resolution Raw	0 - 200 G peak
Mid Resolution Raw	0 - 60 G peak
High Resolution Raw	0 - 20 G peak
Accuracy	All measurements > 10% of reading at levels > 5 G peak All measurements > 10% of reading at levels < 5 G peak

DDS applications include:

- ✓ Monitor whirl
- ✓ Monitor torsional vibration (slip stick)
- ✓ Monitor axial vibration (bit bounce)
- ✓ Detect lateral shock

Frequency response of the accelerometer determines the high frequency cutoff of the DDS sensor. A typical high frequency value is 2300 Hz. The low frequency response is determined by a high pass filter found in the DDS electronics. The filter is set at a -3 db cutoff at 0.5 Hz. The overall frequency response of DDS is typically 0.5 Hz to 2300 Hz.

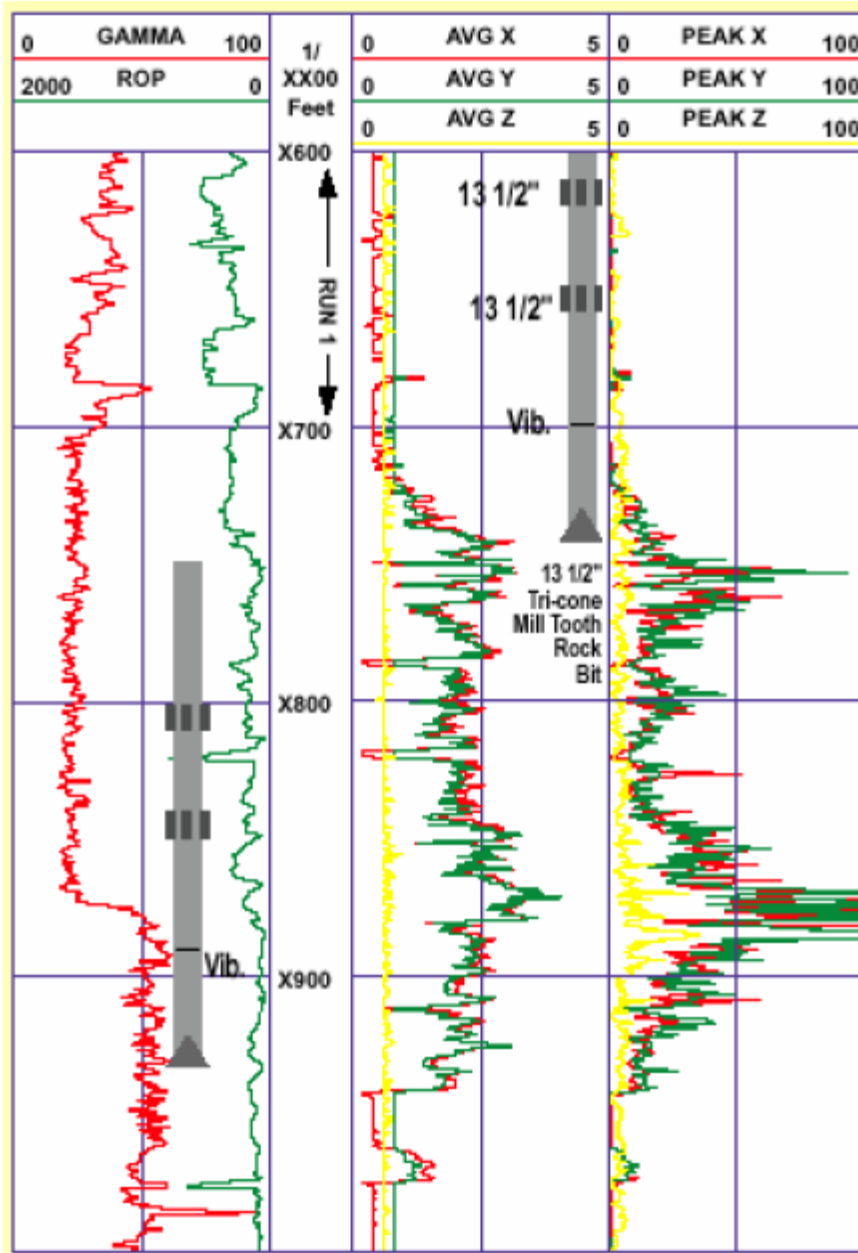

Plot of downhole vibration, natural gamma ray, and ROP

### Weight on Bit/Torque on Bit (WOB/TOB)

Weight on Bit/Torque on Bit (WOB/TOB) is a sensor that can provide real time indications of downhole conditions which can lead to drilling problems such as:

- ✓ Stuck pipe
- ✓ Drill string failures
- ✓ Poor rate of penetration
- ✓ Stick slip
- ✓ Bit and BHA whirl

WOB/TOB has a series of strain gauges that measure axial load, as well as torsion and bending. In addition to the strain gauges, the WOB/TOB sensor also includes the PWD sensor



package. The comprehensive sensor array provides annular and internal pressure, annular fluid temperature, and vibration measurements. WOB/TOB works in conjunction with the DDS sensor and is particularly effective in extended reach and horizontal drilling applications.



WOB/TOB sensor

WOB/TOB applications include:

- ✓ Identifies possible stuck pipe conditions
- ✓ Increases bit performance and reduces bit wear
- ✓ Reduces the amount of time required to diagnose and correct drilling problems
- ✓ Improves drilling efficiency

WOB/TOB Sensor Response

Parameter	Specification
System Maximum Value	Weight: 160,000 lb Torque: 60,000 ft-lb
System Resolution	Weight: 500 lb Torque: 500 ft-lb
Accuracy	WOB: +/- 20% TOB: +/- 20%

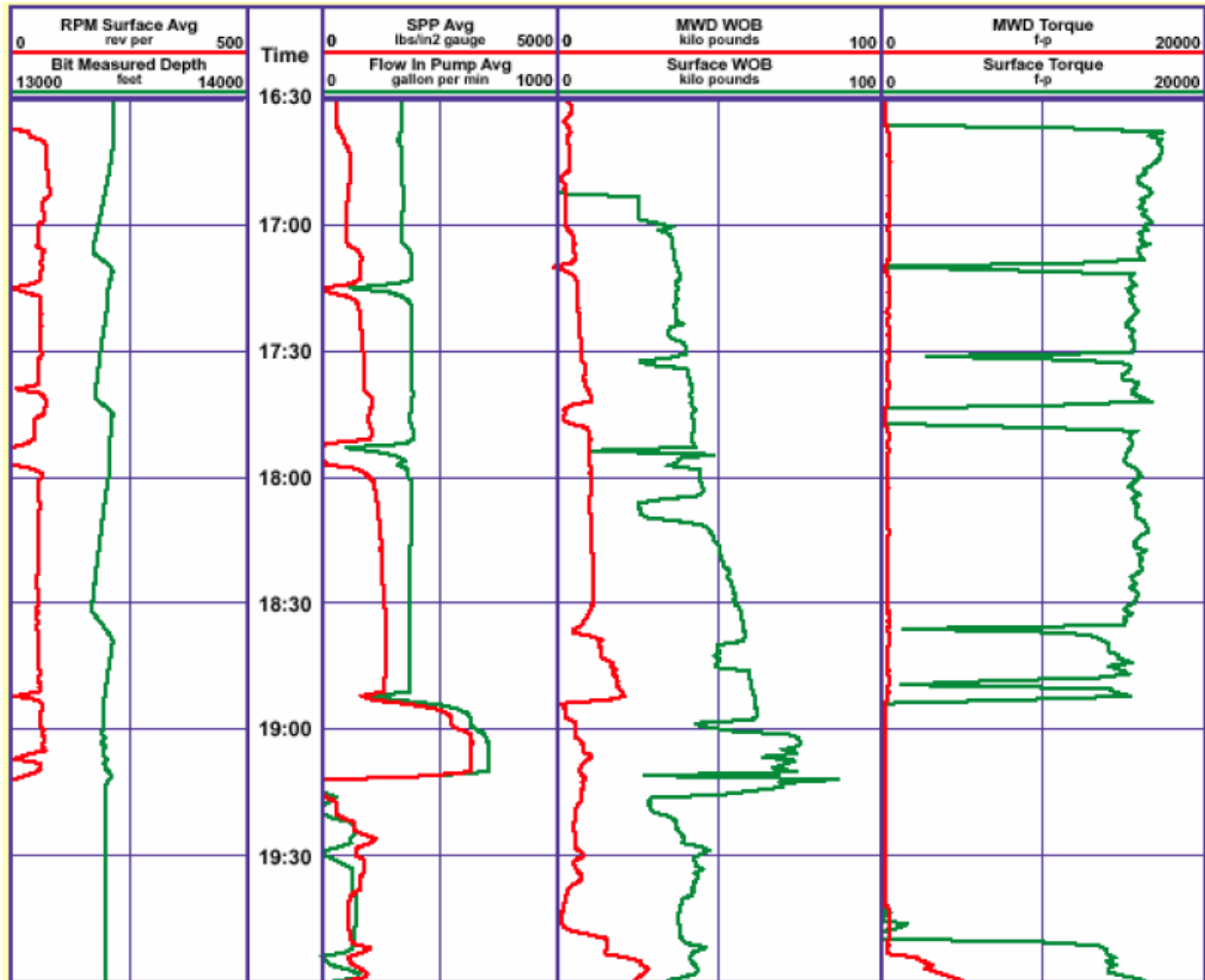

WOB/TOB sensor log showing comparison of downhole and surface weight on bit and torque

### AcoustiCaliper (ACAL)

As mentioned in the Formation Evaluation sensor section of this chapter, the AcoustiCaliper (ACAL) MWD tool is used to improve drilling efficiency by providing real-time borehole diameter measurements. This allows improved ECD calculations, borehole stability, directional control, and BHA dynamics. The ACAL tool is self-contained and has its own processor, memory, and power supply, as well as a communications port and dynamic directional sensors. The three ultrasonic transceivers calculate the size of the borehole while sliding or rotating. These transceivers also calculate the borehole's ellipticity.

Drilling applications include:

- ✓ Measures larger borehole diameter than standoff tools
- ✓ Operates in standalone mode
- ✓ Provides maximum horizontal stress field orientation (based on borehole ellipticity)
- ✓ Provides real-time assessment of wellbore stability
- ✓ Accurately locates tight spots or ledges
- ✓ Provides enhanced assessment of directional drilling tendencies
- ✓ Yields accurate cement volume estimates

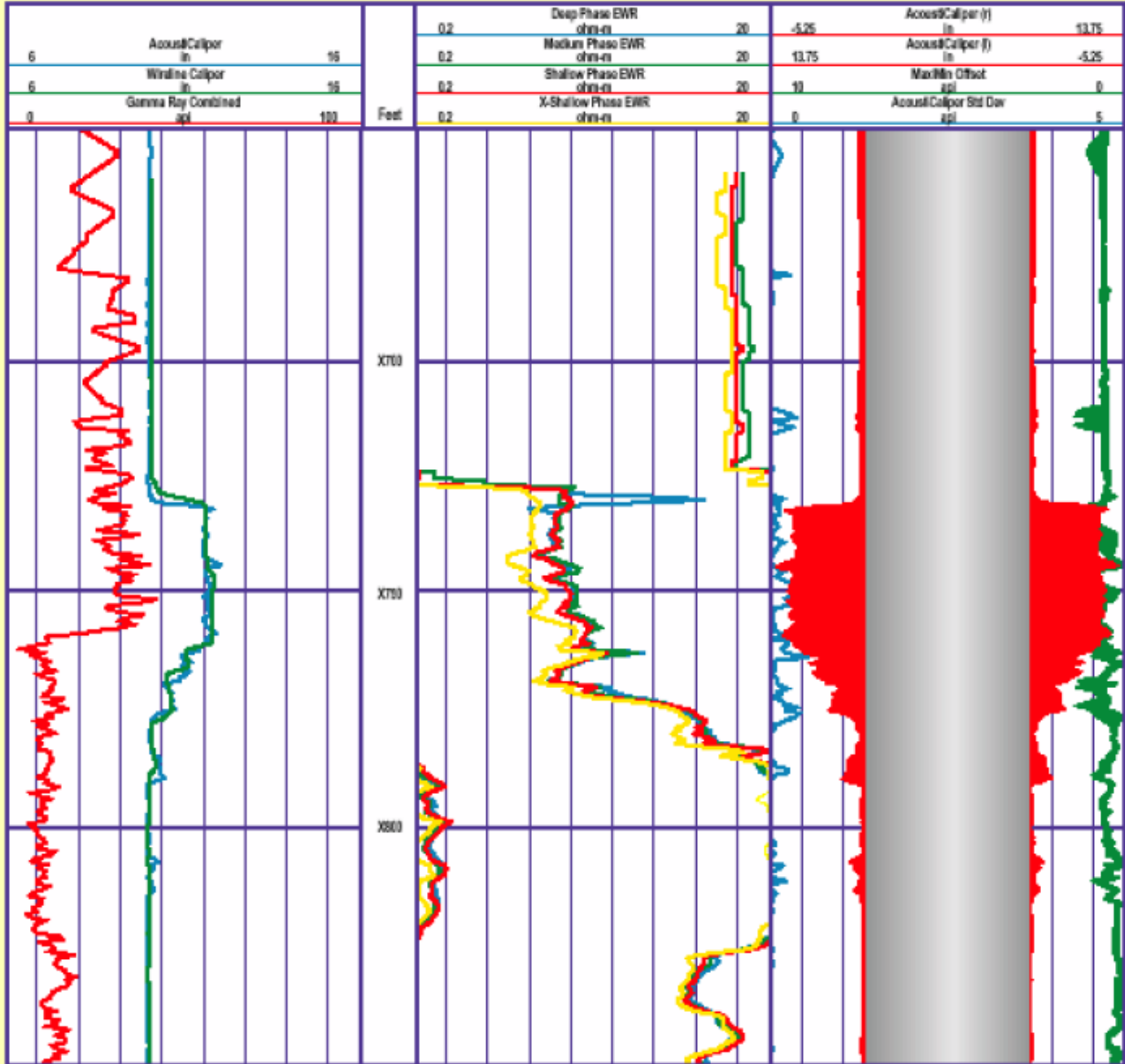

Example of AcoustiCaliper MWD tool vs. wireline, which shows close agreement between the measurements

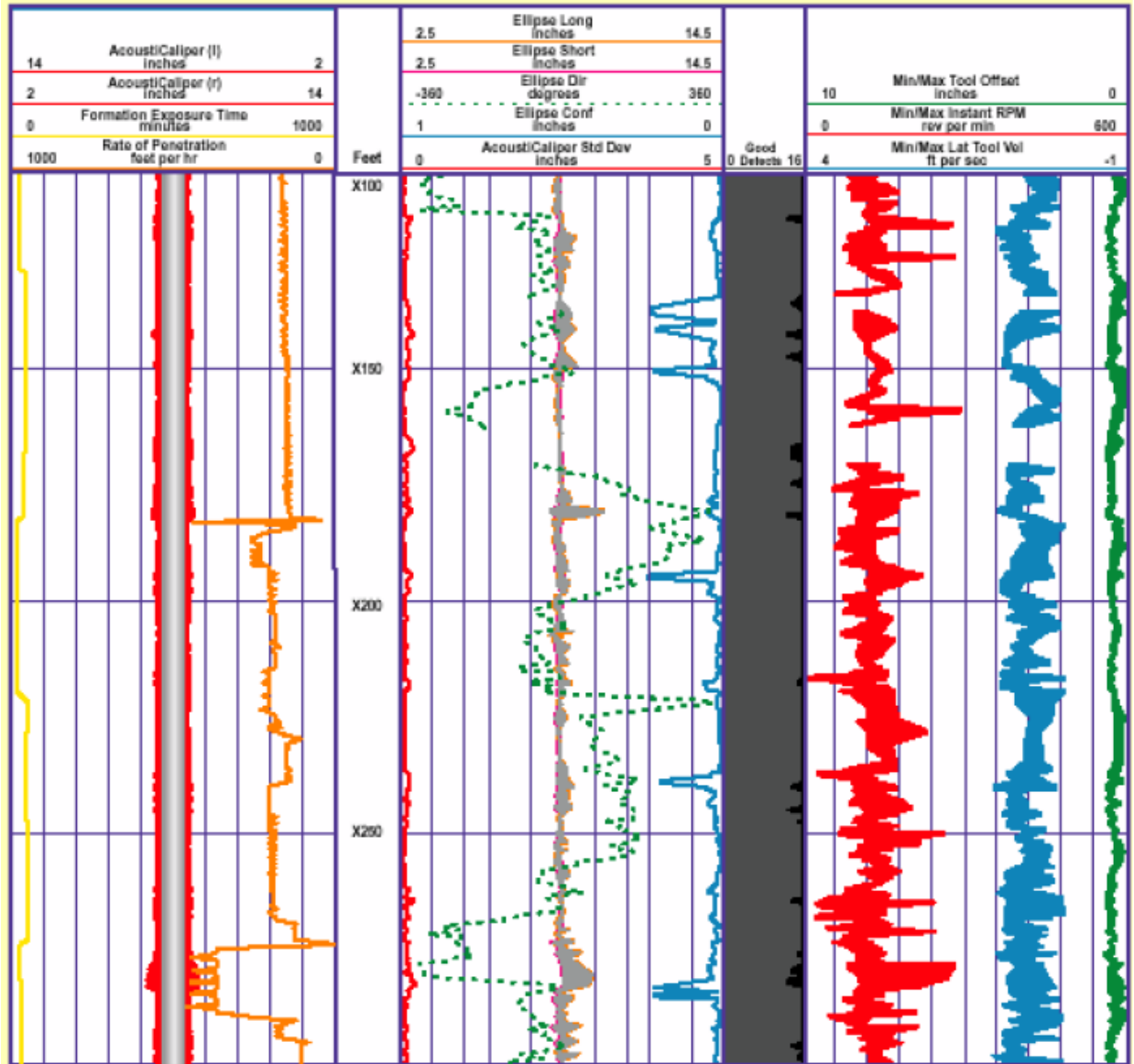

AcoustiCaliper MWD tool elliptical borehole measurements and BHA dynamics

## Log Paper

- ✓ Linear / Linear / Linear
- ✓ Linear / Logarithmic / Linear
- ✓ Linear / Logarithmic / Logarithmic

## Log Format

← TRACK 1 →

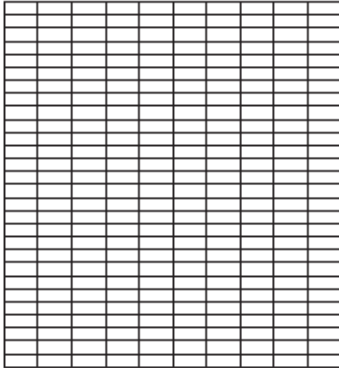

Lin-Lin-Lin

← TRACK 2 → TRACK 3 →

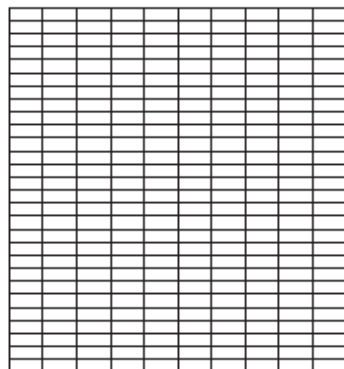
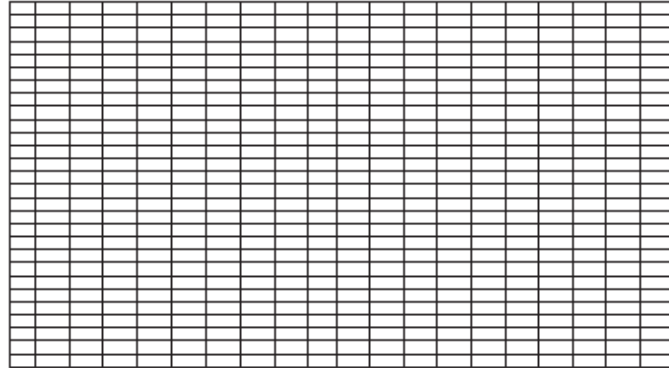

Lin-Log-Log

0.2 1 10 100 1000 2000

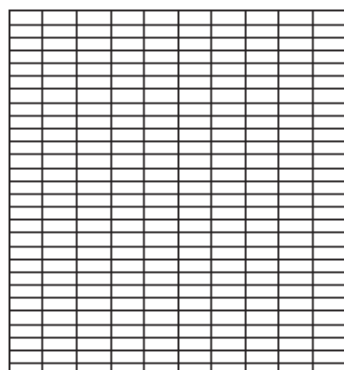
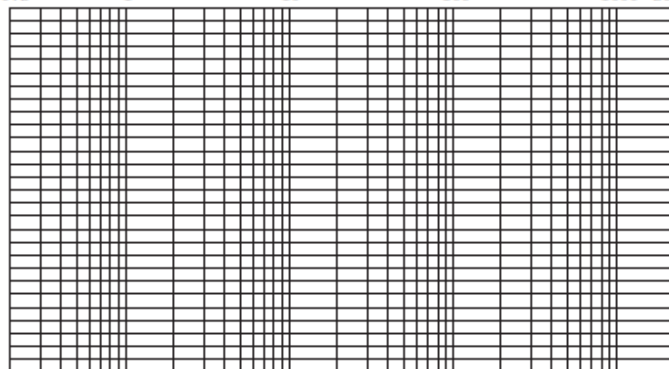

Lin-Log-Lin

0.2 1 10 20

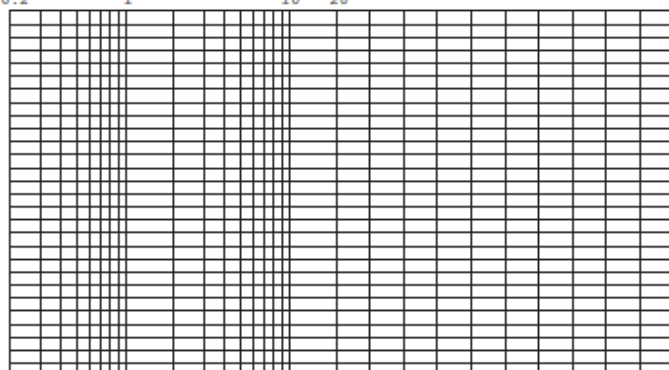

## Log Scales by Track

Lithology Data	Value	Units	Line Type
GR	10 - 110	AAPI	dash or solid
ROP	1000 - 0	ft/hr	dash
CAL	8 - 18	inches	dot

Resistivity Data	Value	Units	Line Type
EWR	.2 - 20	ohm-m	solid

Porosity Data	Value	Units	Line Type
CNP	60 - 0	pu	dash
SLD	1.65 - 2.65	g/cc	solid
Sonic	60 - 0	pu	dot
FET		hours	dash

# Sample Log

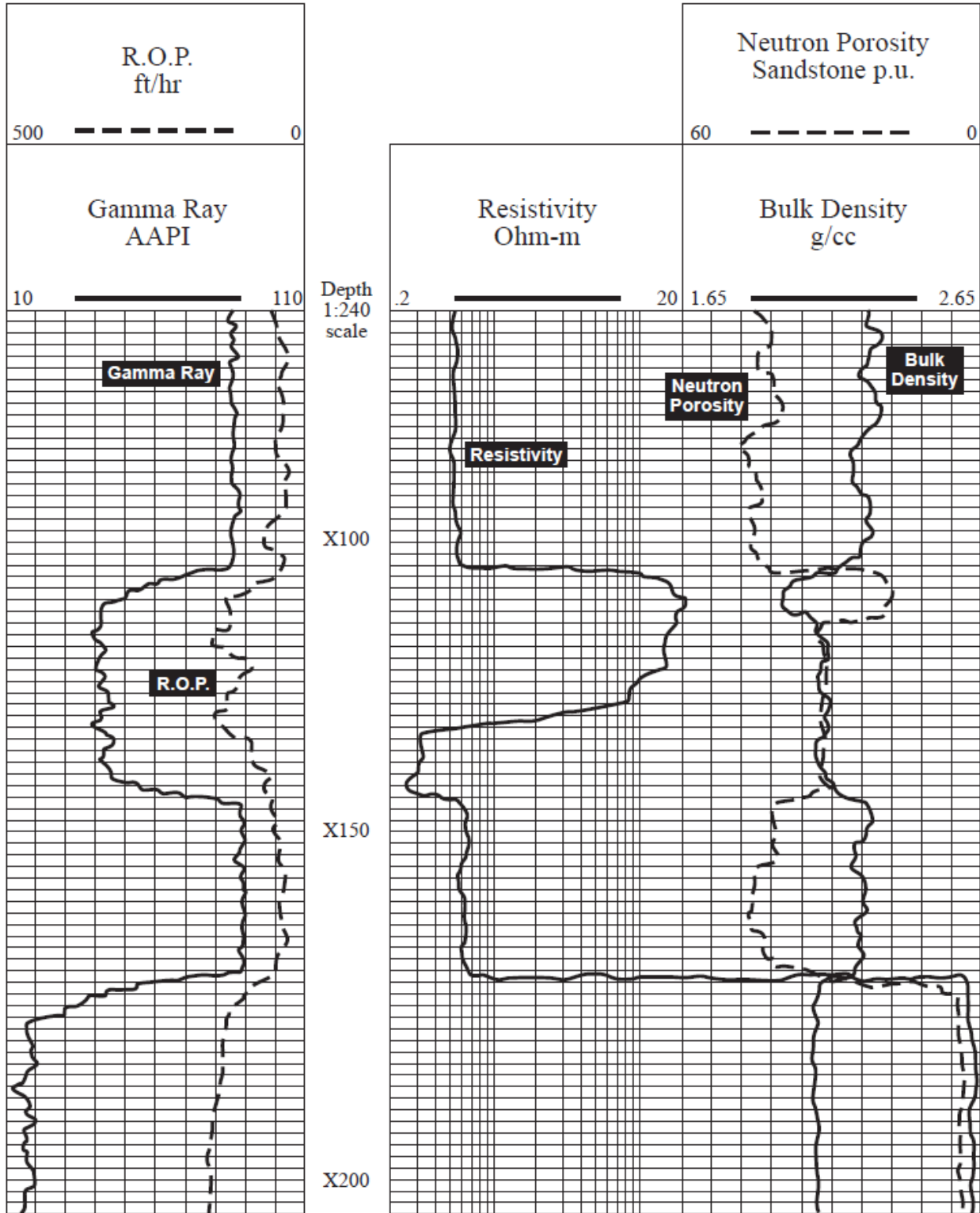

## Formation Pore Pressure

Formation pore pressure is the fluid pressure of the native fluids (water, oil, gas) found within the pore spaces of a formation. Formation pore pressure can be expressed as an average vertical pressure gradient and as an equivalent mud weight. Formation pore pressure gradients and equivalent mud weights are a function of formation vertical depth.

A balanced condition results when the bottom hole pressure is equal to the formation pore pressure. One of the goals of pore pressure prediction is to drill as close to balanced as possible to achieve minimum drilling costs with adequate pressure control. In practice, it is difficult to impossible to continually drill in a balanced condition.

An underbalanced condition results when bottom hole pressure is less than formation pressure. Some wells are drilled underbalanced with rotating heads to minimize drilling cost by maximizing drilling rate.

An overbalanced condition results when the bottom hole pressure is greater than formation pore pressure. Wells are usually drilled slightly overbalanced to ensure pressure control and borehole stability.

A normal condition results when formation fluids are free to migrate to the surface at a rate sufficient to relieve any pressures greater than the hydrostatic pressure of the pore fluids, i.e., an open system. Normal formation pore pressure gradients are the result of normal formation pore fluid densities defined for specific areas.

Gradient (PSI/FT)	Density (PPG)	PPM CL <sup>-</sup>	Fluid Area
0.442	8.50	Fresh	Rocky Mountains Brunei Malaysia Sverdrup
0.452	8.70	40,000	North Sea Delaware (Older portion - pre Pennsylvanian)
0.465	8.94	80,000	Gulf of Mexico
0.478	9.20	95,000	Iran
0.493	9.50	130,000	Saudi Arabia

### Examples of Reported Formation Pore Pressure Gradient Values

Normal formation pore fluid density is the density of the fluid defined as normal for a specific area. Normal fluid densities are determined by experience as those required to balance formation pore pressure when the condition of normal formation pore pressure is known to exist. In practice, normal formation pore pressure and pore pressure gradient are the result of normal fluid densities defined by experience.

Normal formation pressure is calculated by using the following formula:

Normal FP = Formation Water Gradient × True Vertical Depth of Interest



Abnormal formation pore pressure is defined as formation pore pressure greater than normal. The term is used to classify formation pressure without having to specify its exact value. Abnormal formation pore pressure may be expressed in terms of normal formation pore pressure, normal formation pore pressure gradient, or normal formation pore pressure equivalent mud weight. An abnormally pressured formation is a closed system; a closed system is necessary to prevent leak-off of pore fluids and the return of pore pressure to normal.

When shale permeability drops to near zero, formation fluids become trapped in the pore spaces. Any further compaction of the formation will pressurize the shale pore fluids and produce higher than normal formation pressure. Over geologic time (millions of years), the high pressure pore fluid is squeezed from the shale to the adjacent formations (sand, limestone, etc.).

Sub-normal formation pore pressure describes formation pore pressure less than normal. Worldwide sub-normal formation pore pressures occur less frequently than abnormal formation pore pressures. Sub-normal formation pressure may exist in offshore basins due to production depletion; however, naturally occurring subnormal pressure is rare. Sub-normal pressures present unique problems to drilling operations, such as borehole stability, lost circulation, and pressure control.

Note: Wellbores exposed to both sub-normal and abnormal formation pore pressures in uncased sections are subject to both surface and underground blowouts.

We use both resistivity and gamma ray curves on the plot to identify abnormally pressured zones. The gamma ray curve allows us to identify thick (20 feet) shale zones. Shale zones are used because they are impermeable. Shale resistivity will increase normally if water is allowed to escape, as in an open system. Abnormally pressured zones contain more water because they are closed systems and shale resistivity will decrease (move left on plot). This is illustrated in the figure shown below:

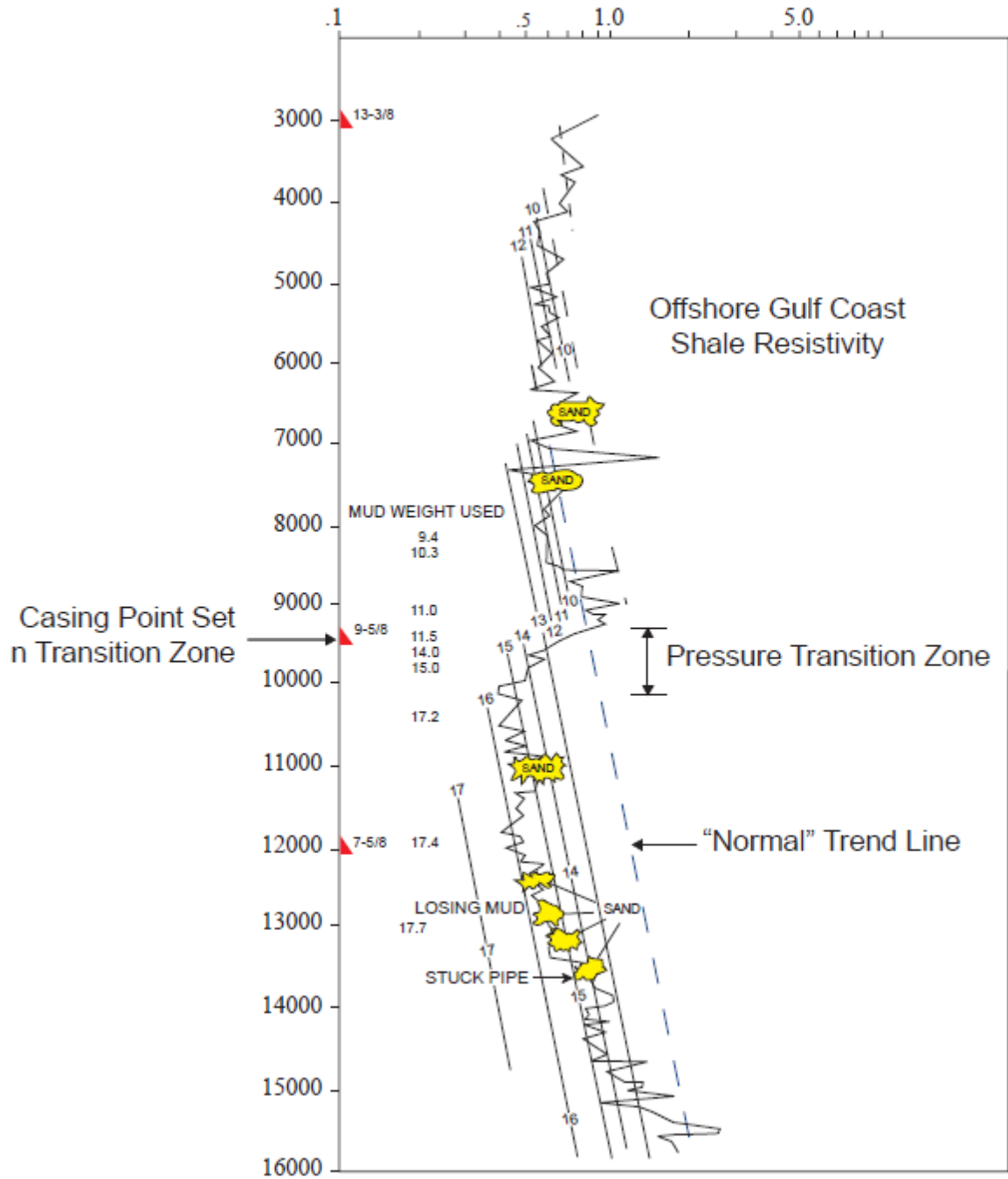

Using Shale Resistivity to Determine an Overpressured Zone

We can also compare the interval transit time of shale using an acoustic tool with the normal formation pressure trend line to identify overpressured zones, as shown in the figure below.

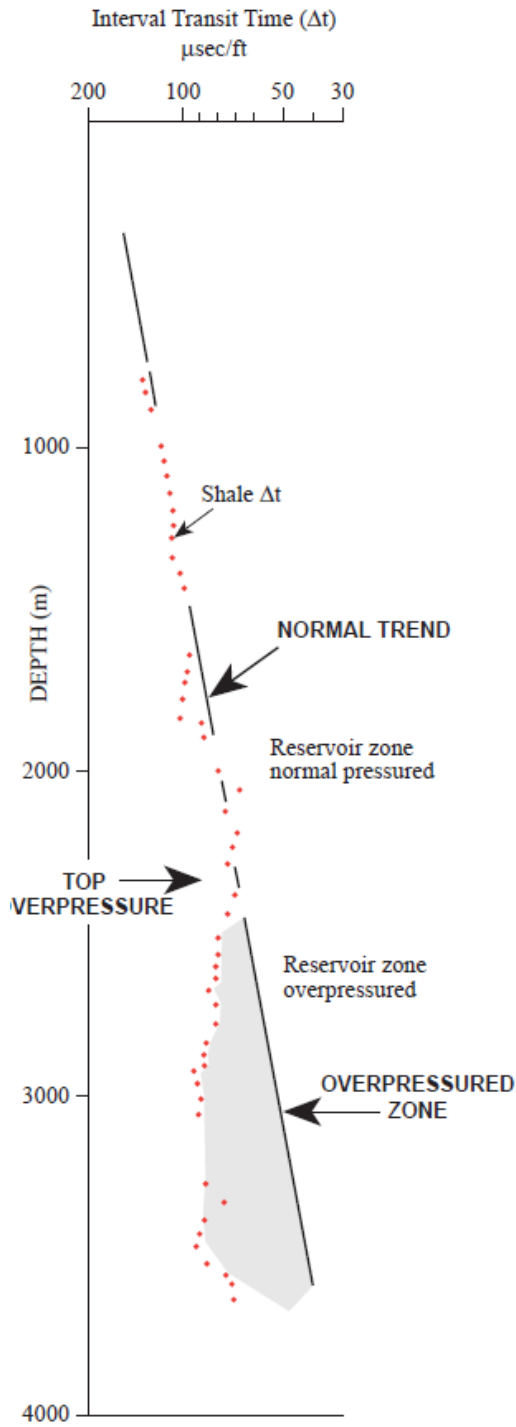

Using an Acoustic Log to Predict Abnormal Formation Pressure

We can also use a density log to predict abnormal formation pressure. In this case, overpressured zone shows higher porosity values than the normal porosity trend.

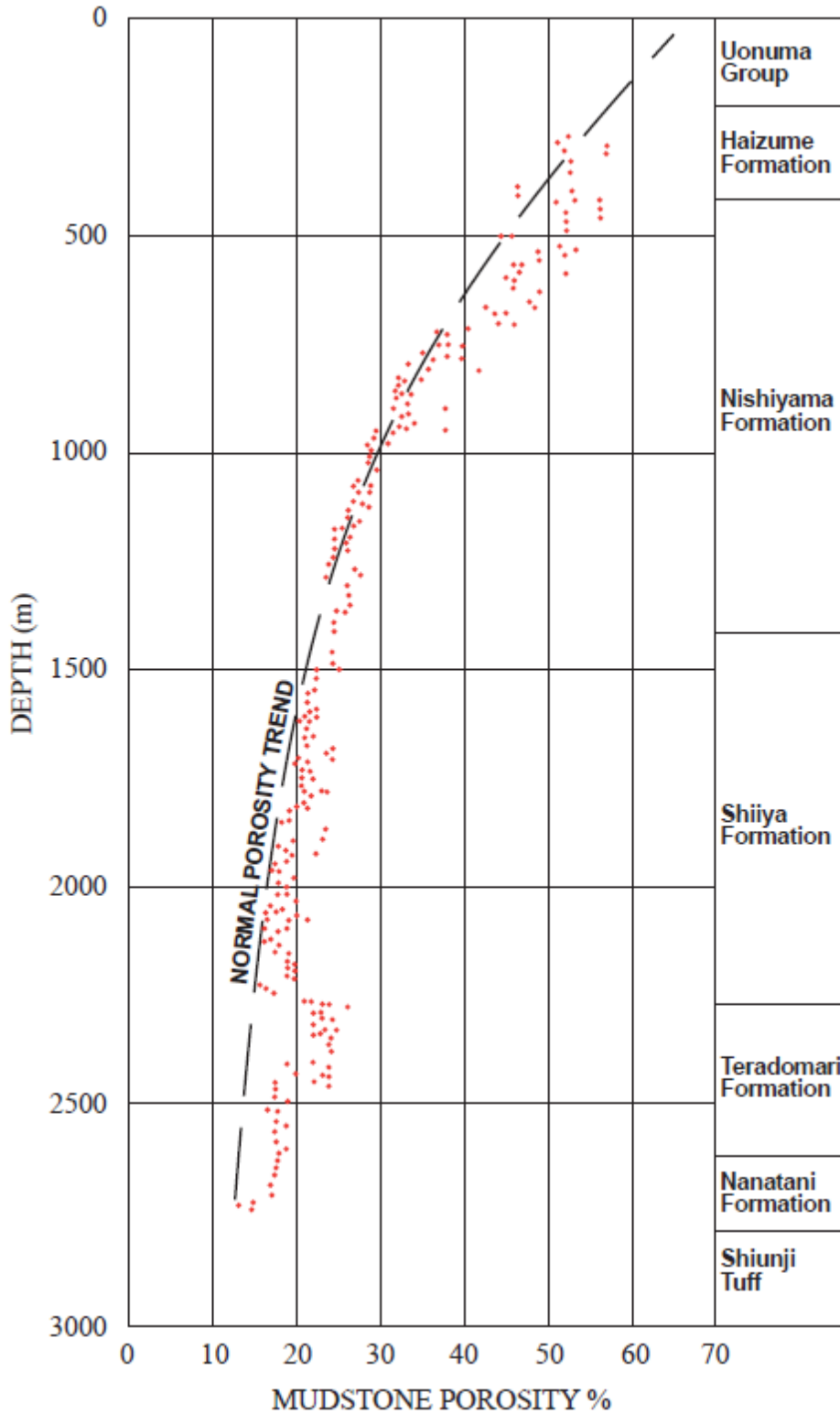

Using a Density Log to Predict Abnormal Formation Pressure

## **CONCLUSION:**

Thus Logs are an explorationist's eye and formation evaluation is very important for reservoir characterization, description and petrophysical analysis. Log measurements, can give the majority of the parameters required by all. Specifically, logs can provide either a direct measurement or a good indication of porosity, both primary and secondary (fractures and vugs), permeability, water saturation and hydrocarbon movability, hydrocarbon type (oil, gas, or condensate), lithology, formation (bed) dip and strike, sedimentary environment, travel times of elastic waves in a formation and etc.

From this data, it is possible to obtain good estimates of the reservoir size and the petroleum hydrocarbons in place.

Logging techniques in cased holes can provide much of the data needed to monitor primary production and also to gauge the applicability of water flooding and to monitor its progress when activated.

In producing wells, logging can provide measurements of flow rates, fluid type, pressure, residual oil saturation. From these measurements, dynamic well behavior can be better understood, remedial work can be planned and secondary or tertiary recovery proposals can be evaluated and monitored.

In summary, when logging is properly applied, it can help to answer a great many questions from a wide spectrum of special interest groups on topics ranging from basic geology to economics. Of equal importance, however, is the fact that logging by itself cannot provide answers to all formation evaluation questions. Coring, core analysis, and formation testing are integral parts of any formation evaluation effort. This is an instrument which gives maximum information at a very minimal cost. This also acts as a driller's tool during complication- a third hand for a completion engineer. Thus no hydrocarbon can be produced without the intervention of Logs, Petrophysical Analysis, Reservoir Characterization and Formation Evaluation.